

Access ANPR Camera

User's Manual



V1.0.3





Foreword

General

The manual introduces the structure, installation, functions, and operations of the access ANPR camera (hereinafter referred to as "the Camera").

Safety Instructions

The following signal words might appear in the manual.

Signal Words	Meaning
 DANGER	Indicates a high potential hazard which, if not avoided, will result in death or serious injury.
 CAUTION	Indicates a potential risk which, if not avoided, could result in property damage, data loss, reductions in performance, or unpredictable results.
 TIPS	Provides methods to help you solve a problem or save time.
 NOTE	Provides additional information as a supplement to the text.

Revision History

Revision Content	Release Time	Revision Content
V1.0.3	Updated manual format.	October 2021
V1.0.2	Updated the focal length of 437 and 415 models of camera.	July 2021
V1.0.1	Added more models.	March 2021
V1.0.0	First release.	November 2019

Privacy Protection Notice

As the device user or data controller, you might collect the personal data of others such as their face, fingerprints, and license plate number. You need to be in compliance with your local privacy protection laws and regulations to protect the legitimate rights and interests of other people by implementing measures which include but are not limited: Providing clear and visible identification to inform people of the existence of the surveillance area and provide required contact information.

About the Manual

- The manual is for reference only. Slight differences might be found between the manual and the product.
- We are not liable for losses incurred due to operating the product in ways that are not in compliance with the manual.
- The manual will be updated according to the latest laws and regulations of related jurisdictions. For detailed information, see the paper user's manual, use our CD-ROM, scan the QR code or visit our official website. The manual is for reference only. Slight differences might be found between the electronic version and the paper version.

- All designs and software are subject to change without prior written notice. Product updates might result in some differences appearing between the actual product and the manual. Please contact customer service for the latest program and supplementary documentation.
- There might be errors in the print or deviations in the description of the functions, operations and technical data. If there is any doubt or dispute, we reserve the right of final explanation.
- Upgrade the reader software or try other mainstream reader software if the manual (in PDF format) cannot be opened.
- All trademarks, registered trademarks and company names in the manual are properties of their respective owners.
- Please visit our website, contact the supplier or customer service if any problems occur while using the device.
- If there is any uncertainty or controversy, we reserve the right of final explanation.

Important Safeguards and Warnings

This section introduces content covering the proper handling of the device, hazard prevention, and prevention of property damage. Read carefully before using the device, comply with the guidelines when using it, and keep the manual safe for future reference.

Transportation Requirements



Transport the device under allowed humidity and temperature conditions.

Storage Requirements



Store the device under allowed humidity and temperature conditions.

Installation Requirements



- Do not connect the power adapter to the device while the adapter is powered on.
- Strictly comply with the local electrical safety code and standards. Make sure the ambient voltage is stable and meets the power supply requirements of the device.
- Do not connect the device to two or more kinds of power supplies, to avoid damage to the device.



- Personnel working at heights must take all necessary measures to ensure personal safety including wearing a helmet and safety belts.
- Do not place the device in a place exposed to sunlight or near heat sources.
- Keep the device away from dampness, dust, and soot.
- Put the device in a well-ventilated place, and do not block its ventilation.
- Use an adapter or cabinet power supply provided by the manufacturer.
- The power supply must conform to the requirements of ES1 in IEC 62368-1 standard and be no higher than PS2. Please note that the power supply requirements are subject to the device label.
- The device is a class I electrical appliance. Make sure that the power supply of the device is connected to a power socket with protective earthing.
- An emergency disconnect device must be installed during installation and wiring at a readily accessible location for emergency power cut-off.
- Disconnect the device when installing and connecting the lens.

Operation Requirements



- Make sure that the power supply is correct before use.
- Do not unplug the power cord on the side of the device while the adapter is powered on.
- Operate the device within the rated range of power input and output.
- Use the device under allowed humidity and temperature conditions.

- Do not drop or splash liquid onto the device, and make sure that there is no object filled with liquid on the device to prevent liquid from flowing into it.
- Do not disassemble the device.
- Do not aim the device at strong light sources (such as lamplight, and sunlight) when focusing it.
- Do not vibrate, squeeze or immerse the device in liquid during transportation, storage or installation.
- Do not block the ventilation near the device.
- We recommend you use the device with a lightning protection device for stronger protection against lightning. For outdoor scenarios, strictly comply with the lightning protection regulations.
- Ground the function earthing portion of the device (grounding cable or lightning surge protector) to improve its reliability. The device is a class I electrical appliance. Make sure that the power supply of the device is connected to a power socket with protective earthing.
- The device must be used with the protective cover for outdoor scenarios to avoid the risk of water damage to the device.
- Protect the line cord and wires from being walked on or squeezed particularly at plugs, power sockets, and the point where they exit from the device.
- Modify the default password of the device after first-time login to prevent the device from being stolen.

Maintenance Requirements

- Pack the device with packaging provided by its manufacturer or packaging of the same quality before sending it back for repair.
- Please do not touch the photosensitive device with your hands. Use an air blower to clean off the dust and filth on the lens.
- Clean the surface of the device with a soft dry cloth or a clean soft cloth dipped in neutral detergent.
- Use the accessories suggested by the manufacturer. Installation and maintenance must be performed by qualified professionals.

Table of Contents

Foreword	I
Important Safeguards and Warnings.....	III
1 Introduction	1
1.1 Overview	1
1.2 Features.....	1
2 Structure	3
2.1 Long Range ANPR Camera Dimensions.....	3
2.2 Short Range ANPR Camera Dimensions.....	3
2.3 Structure	4
2.3.1 Entire Device	4
2.3.2 Rear Panel.....	5
2.4 Cable Connection.....	5
3 Installation.....	9
3.1 Universal Joint Installation.....	9
3.2 Spherical Bracket Installation	9
4 Web Configuration	11
4.1 Web Login.....	11
4.1.1 Recommended Configuration.....	11
4.1.2 Device Initialization.....	11
4.1.3 Login	14
4.1.4 Resetting Password	15
4.1.5 Web Functions.....	17
4.2 Guide.....	18
4.3 Live.....	20
4.3.1 Video Stream.....	21
4.3.2 Live View	21
4.3.3 Logged Plate Number.....	22
4.3.4 Plate Snapshot	22
4.3.5 System Functions.....	22
4.3.6 Functions of the Live Page	22
4.3.7 Vehicle Snapshot	24
4.3.8 Event List.....	25
4.4 Query	25
4.4.1 Image Search.....	25
4.4.1.1 SD Picture.....	25

4.4.1.2 Image Downloading Attribute	26
4.4.1.3 PC Picture	27
4.4.2 Recording Search	27
4.4.2.1 Record	27
4.4.2.2 Watermark	28
4.4.3 Capture Record Search	28
4.4.4 Alarm Output Search	29
4.5 Setting	29
4.5.1 ITC	30
4.5.1.1 Detection	30
4.5.1.1.1 Snapshot	30
4.5.1.1.2 IO	31
4.5.1.2 Intelligence	32
4.5.1.2.1 Recognition	32
4.5.1.2.2 Scene	33
4.5.1.2.3 Advance Configuration	34
4.5.1.3 OSD Configuration	34
4.5.1.3.1 Video OSD	34
4.5.1.3.2 Snap OSD	36
4.5.1.4 Cutout Configuration	37
4.5.1.4.1 Snapshot Cutout	37
4.5.1.4.2 Face Overlap	38
4.5.1.5 Blocklist and Allowlist	38
4.5.1.5.1 Fuzzy Matching	38
4.5.1.5.2 Allowlist	39
4.5.1.5.3 Blocklist Search	41
4.5.1.5.4 Barrier Control	41
4.5.1.6 RS-485	42
4.5.1.7 RS-485 LED Display	44
4.5.1.8 Voice Broadcast	45
4.5.1.8.1 Broadcast Content	45
4.5.1.8.2 Volume/Encoding	46
4.5.1.9 Device Test	46
4.5.1.9.1 Device Test	46
4.5.1.9.2 Capturing Commissioning	47
4.5.2 Camera	48
4.5.2.1 Attribute	48
4.5.2.1.1 General	48

4.5.2.1.2 Shutter.....	49
4.5.2.1.3 Metering Zone	51
4.5.2.2 Video	51
4.5.2.2.1 Video	51
4.5.2.2.2 Snapshot.....	53
4.5.2.2.3 Interest Area.....	53
4.5.3 Network.....	54
4.5.3.1 TCP/IP.....	54
4.5.3.2 Connection.....	55
4.5.3.2.1 Port.....	55
4.5.3.2.2 ONVIF	56
4.5.3.3 Auto Register	57
4.5.3.4 SMTP (Email).....	58
4.5.3.5 IEEE802.....	59
4.5.3.6 ITC Push	60
4.5.4 Event	61
4.5.4.1 Alarm.....	61
4.5.4.1.1 Relay Activation.....	61
4.5.4.1.2 Relay-out	63
4.5.4.2 Abnormality.....	63
4.5.5 Storage.....	64
4.5.5.1 Point	65
4.5.5.2 Local.....	65
4.5.5.3 FTP	65
4.5.5.4 Client	67
4.5.5.5 Save Path.....	67
4.5.6 System.....	68
4.5.6.1 General.....	68
4.5.6.1.1 General Setup	68
4.5.6.1.2 Date & Time.....	69
4.5.6.2 Account.....	70
4.5.6.2.1 Account	70
4.5.6.2.2 ONVIF User	72
4.5.6.3 Safety.....	74
4.5.6.3.1 System Service.....	74
4.5.6.3.2 HTTPS.....	75
4.5.6.3.3 Firewall.....	78
4.5.6.4 Default Settings.....	79

4.5.6.5 Import/Export.....	79
4.5.6.6 Automatic Maintenance.....	79
4.5.6.7 System Upgrade.....	80
4.5.7 Information.....	80
4.5.7.1 Version.....	80
4.5.7.2 Log.....	81
4.5.7.2.1 System Log.....	81
4.5.7.2.2 Remote log.....	82
4.5.7.2.3 Operation Log Collection.....	82
4.5.7.3 Online User.....	83
4.5.7.4 Running Status.....	83
4.6 Alarm.....	83
4.7 Logout.....	84
5 FAQ.....	85
Appendix 1 Cybersecurity Recommendations.....	86

1 Introduction

1.1 Overview

The access ANPR camera adopts intelligent deep learning algorithm. It supports vehicle detection, license plate recognition, logo recognition, model recognition, and color recognition, and encoding mode such as H.265.

The Camera consists of protective housing, illuminator, and intelligent HD camera. The intelligent HD camera adopts progressive scanning CMOS, which owns several features such as high definition, low illuminance, high frame rate, and excellent color rendition.

The Camera is extensively applied to vehicle capture, and recognition of community road, parking lot, and other entrance, and exit surveillance.

1.2 Features



The features are available on select modes, and might differ from the actual camera.

Permission Management

- Each user group owns permissions. Permissions of a user cannot exceed the permissions of its group.
- 2 user levels.
- Permission of opening barrier, and blocklist alarm function.
- Device configuration, and permission management through Ethernet.

Storage

- Stores corresponding video data onto the central server according to the configuration (such as alarm, and timing settings).
- Users can record through web according to their requirements. The recorded video file will be stored on the computer where client is located.
- Supports local hot swapping of storage card, and storage when network disconnected. It overwrites stored pictures, and videos automatically when memory becomes insufficient.
- Stores 1024 log records, and user permission control.
- Supports FTP storage, and automatic network replenishment (ANR).

Alarm

- It can trigger alarm upon camera operation exceptions through network, such as memory card damage.
- Some devices can connect to various alarm peripherals to respond to external alarm input in real time (within 200 ms). It can correctly deal with various alarms according to the linkage predefined by users, and generate corresponding voice prompt (users are allowed to record voice in advance).

Network Monitoring

- Transmits video data of single channel compressed by device to network terminal, and make it reappear after decompression through network. Keep delay within 500ms when bandwidth is allowed.
- Supports maximum 10 users online at the same time.
- Supports system access, and device management through web.
- Video data transmission adopts HTTP, TCP, UDP, MULTICAST, and RTP/RTCP.

Capture, and Recognition

- Recognition of number plate, and other vehicle information, including vehicle color, logo, model, and other vehicle features.
- Supports setting OSD information, and configuring location of channel, and picture.
- Supports picture capture, and encoding. Supports picture watermark encryption to prevent pictures from being tampered.
- The captured pictures can automatically record vehicle time, location, license plate, vehicle color, and more.

Peripheral Control

- Peripheral control: Supports setting various peripheral control protocols, and connection pages.
- Connects to external devices such as vehicle detector, signal detector, and more.

Auto Adjustment

- Auto iris: Automatically adjusts the iris opening to the changing light throughout the day.
- Auto white balance: Accurately displays the object color when light condition changes.
- Auto exposure: Automatically adjusts shutter speed according to the exposure value of the image measured by the metering system, and according to shutter, and iris exposure set by factory defaults.
- Auto gain: Automatically increases camera sensitivity when illuminance is very low, enhancing image signal output so that the Camera can acquire clear, and bright image.

2 Structure

2.1 Long Range ANPR Camera Dimensions

Figure 2-1 Camera dimensions (mm [inch])

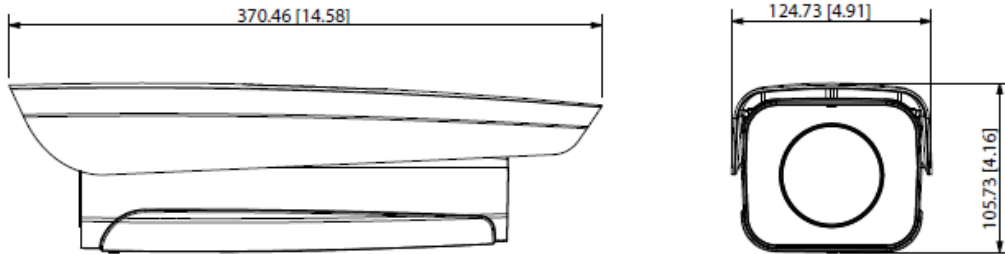
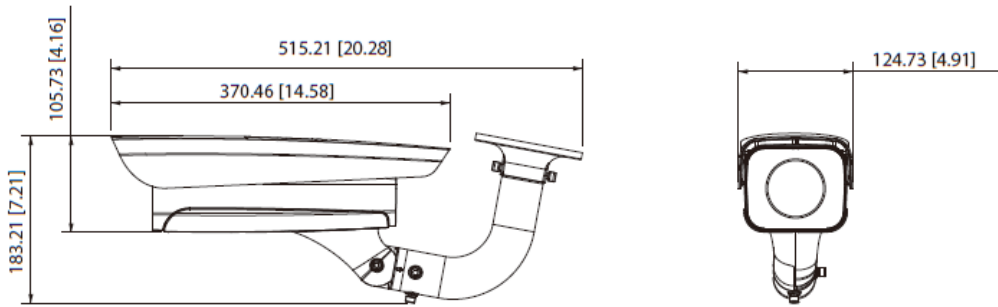

Figure 2-2 Dimensions of camera with bracket (mm [inch])



2.2 Short Range ANPR Camera Dimensions

Figure 2-3 General camera dimensions (mm [inch])

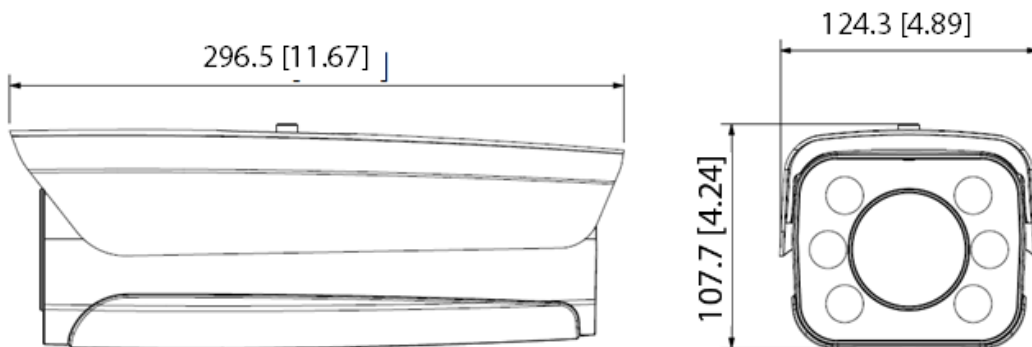

Figure 2-4 Dimensions of camera with bracket (mm [inch])

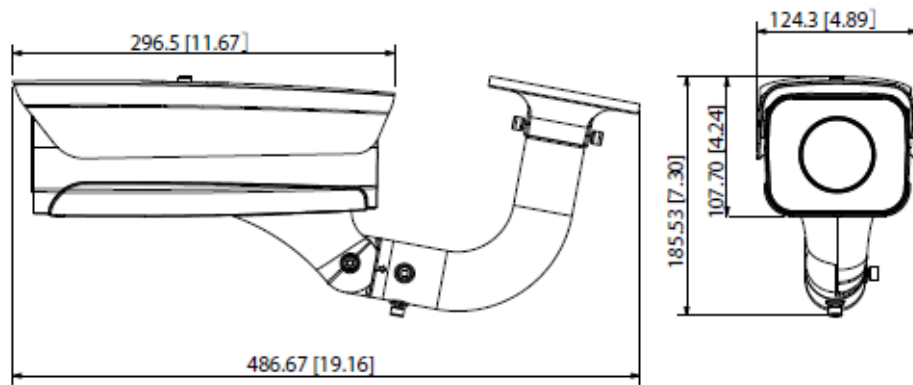
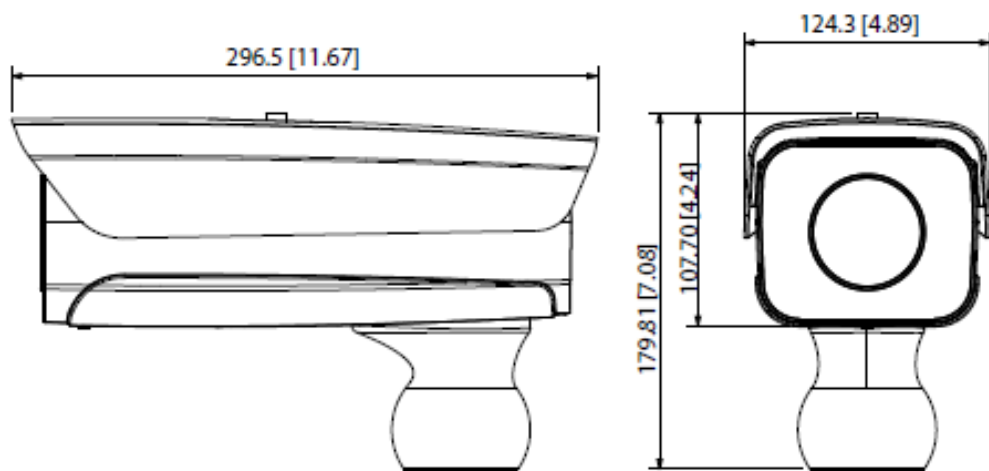

Figure 2-5 Dimensions of camera with spherical bracket (mm [inch])



2.3 Structure

2.3.1 Entire Device

Figure 2-6 Entire device structure

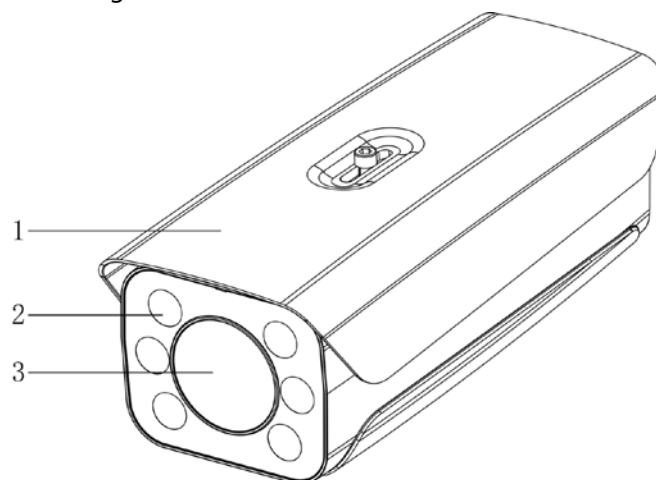

Table 2-1 Camera structure description

No.	Description	No.	Description
1	Protective cover	3	Lens
2	Illuminator	—	

2.3.2 Rear Panel

Figure 2-7 Rear panel structure

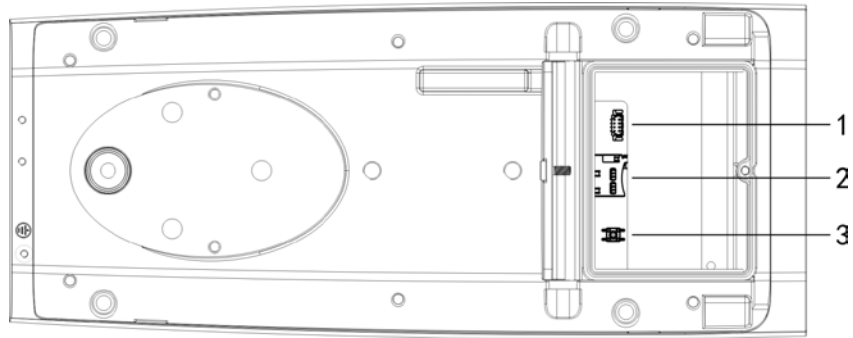

Table 2-2 Description of rear panel structure

No.	Description	No.	Description
1	Debugging port	3	Hardware reset
2	TF card	—	

2.4 Cable Connection

Two cable connection methods are available, and might differ from the actual product.

Figure 2-8 Cable connection (1)

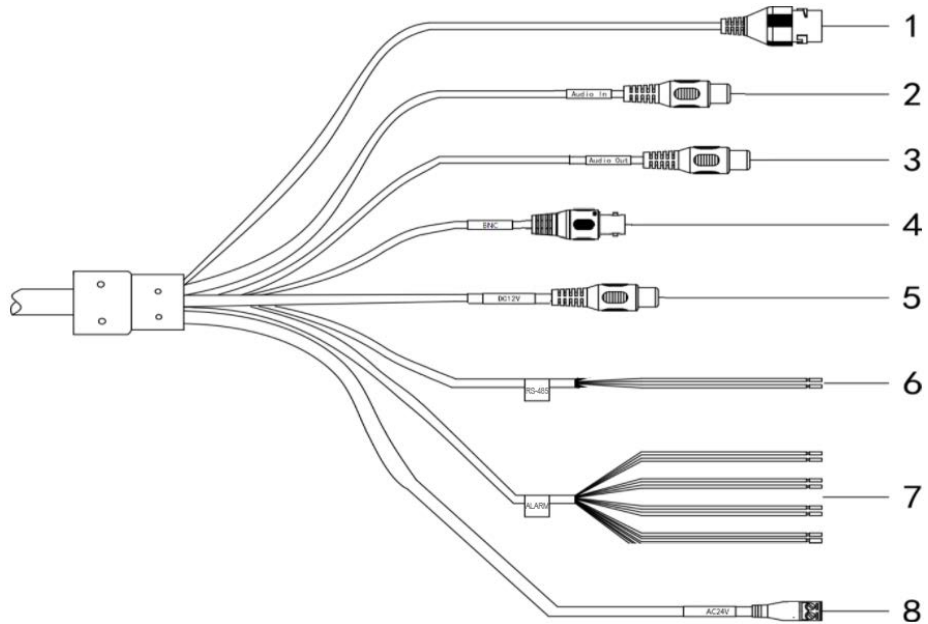

Table 2-3 Cable connection description



No.	Port	Function	Description
1	LAN	Ethernet port	Connects to standard Ethernet, supports PoE power supply.
2	AUDIO OUT	Audio output port	The Camera sends out audio signal through this port.
3	AUDIO IN	Audio input port	The Camera gets audio signal through this port.
4	BNC	Video output port	The Camera sends out video signal through this port.
5	12 VDC	Power input port	Inputs 12 VDC power. Please be sure to supply power as instructed.  Device damage will occur if power is not supplied correctly.
6	RS-485	RS-485 port	<ul style="list-style-type: none"> ● Yellow: RS-485_A1 ● Orange: RS-485_B1
7	ALARM	Alarm port	<ul style="list-style-type: none"> ● Alarm output, connecting to barrier, and alarm output devices such as alarm light. <ul style="list-style-type: none"> ◇ Brown: ALARM_OUT1 ◇ Green: ALARM_OUT_GND1 ◇ Red: ALARM_OUT2 ◇ Black: ALARM_OUT_GND2 ● Alarm input, connecting to vehicle detector, IR detector, induction loop, and more. <ul style="list-style-type: none"> ◇ Blue: ALARM_IN1 ◇ White: ALARM_IN2 ◇ Yellow: ALARM_IN3 ◇ Gray: ALARM_IN_GND
8	24 VAC	Power input port	Inputs 24 VAC power. Please be sure to supply power as instructed.  Device damage will occur if power is not supplied correctly.

Figure 2-9 Cable connection

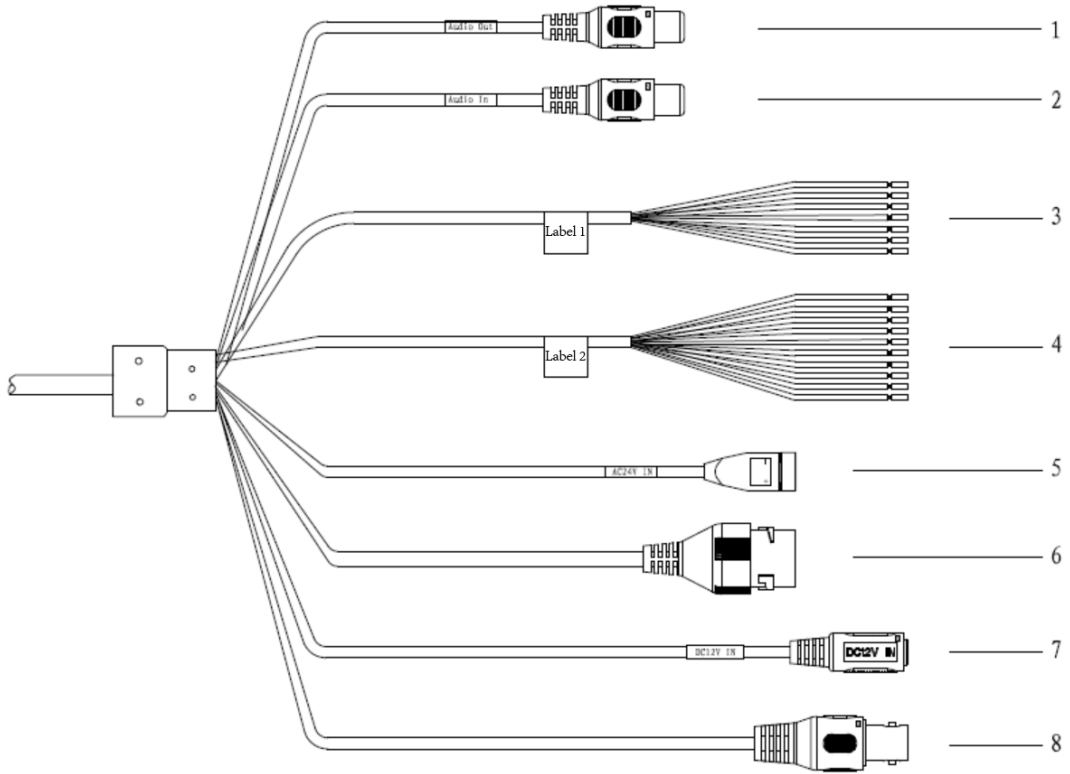



Table 2-4 Cable connection

No.	Port	Function	Description
1	AUDIO OUT	Audio output port	The Camera sends out audio signal through this port.
2	AUDIO IN	Audio input port	The Camera gets audio signal through this port.
3	RS-485/RS-232	RS-485/RS-232 port	<ul style="list-style-type: none"> ● White & Red: RS-485_A1 ● White & Orange: RS-485_B1 ● Yellow & Green: RS-485_A2 ● Yellow & Black: RS-485_B2 ● White & Yellow: RS-232_RXD ● White & Brown: RS-232_TXD ● White & Black: GND

No.	Port	Function	Description
4	ALARM	Alarm port	<ul style="list-style-type: none"> ● Alarm output, connecting to barrier, and alarm output devices such as alarm light. <ul style="list-style-type: none"> ◇ Brown: ALARM_NO1 ◇ Green: ALARM_COM1 ◇ White & Purple: ALARM_NO2 ◇ Light Green: ALARM_COM2 ◇ Red: ALARM_NO3 ◇ Black: ALARM_COM3 ● Alarm input, connecting to vehicle detector, IR detector, induction loop, and more. <ul style="list-style-type: none"> ◇ Blue: ALARM_IN1 ◇ White: ALARM_IN2 ◇ Yellow: ALARM_IN3 ◇ Gray: ALARM_IN_GND
5	24 VAC	Power input port	<p>Inputs 24 VAC power. Be sure to supply power as instructed.</p>  <p>Device damage will occur if power is not supplied correctly.</p>
6	LAN	Ethernet port	Connects to standard Ethernet. Supports PoE power supply.
7	12 VDC	Power input port	<p>Inputs 12 VDC power. Be sure to supply power as instructed.</p>  <p>Device damage will occur if power is not supplied correctly.</p>
8	BNC	Video output port	The Camera sends out video signal through this port.

3 Installation



The following installation figures are for reference only, and might differ from the actual product.

3.1 Universal Joint Installation

Step 1 Use M6×14 screw to fix the universal joint on the bracket.

Step 2 Use two 1/4-20×14UNC screws to fix the Camera on the universal joint. See .

Figure 3-1 Universal joint installation

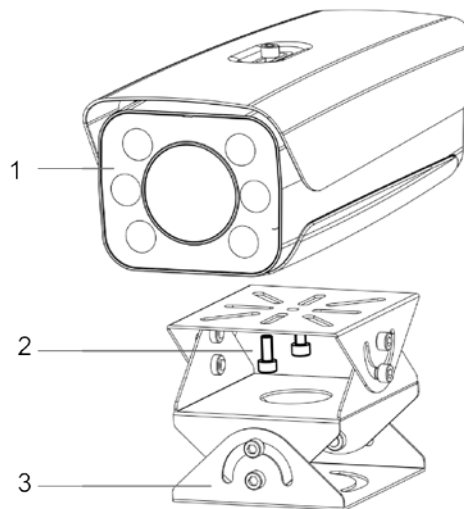

Table 3-1 Camera structure description

No.	Description	No.	Description
1	Camera	3	Universal joint
2	1/4-20×14UNC screw	—	

Step 3 Adjust the universal joint, and the Camera to proper position.

3.2 Spherical Bracket Installation

Step 1 Insert the damping ring, and waterproof ring of cable into the bracket housing.

Figure 3-2 Prepare bracket housing

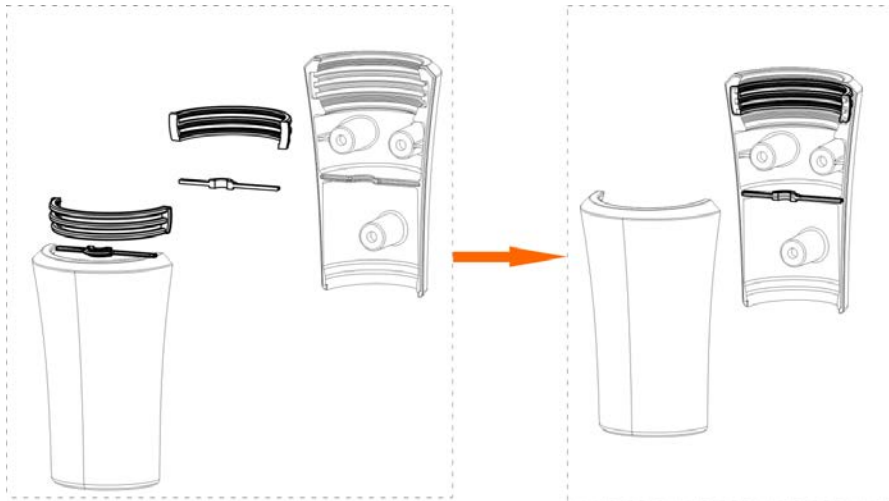

Step 2 Cover the spherical bracket with bracket housing.

Step 3 Use three M6×20 socket head cap screws to fix the bracket housing to the Camera.
For the illustration after installation.

Figure 3-3 Fix the bracket housing

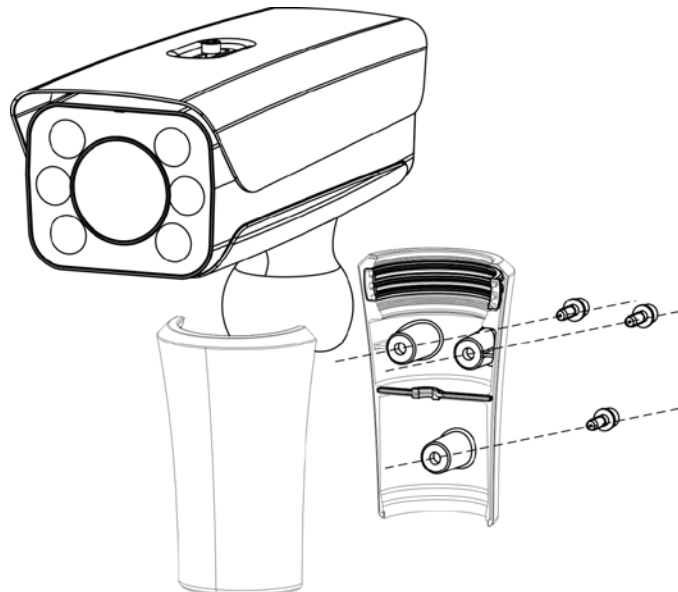
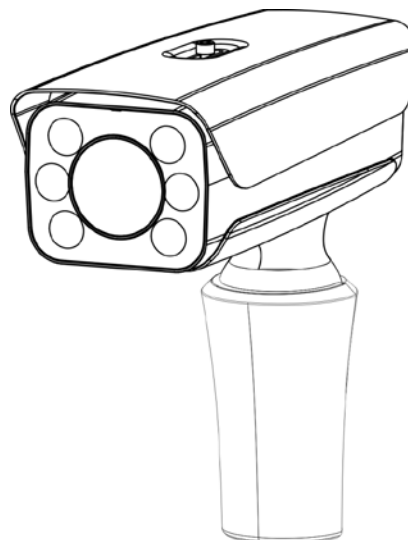

Figure 3-4 Installation completed



4 Web Configuration

It supports logging in to device web page through browser on PC, and realizes device configuration, operation, and management.



The pages, and Settings are for reference only, and might differ from the actual page.

4.1 Web Login

4.1.1 Recommended Configuration

Table 4-1 Recommended PC configuration

PC Component	Recommended Configuration
Operating System	Windows 7, and later
CPU	Intel core i3, and faster processor
Graphics	Intel HD Graphics, and later
RAM	2 GB, and larger
Monitor	1024 × 768, and higher
Browser	Internet Explorer 9/11, Chrome 33/41, Firefox 49

4.1.2 Device Initialization

The Camera is delivered uninitialized by default. You need to initialize it, and change its password before further operations.

Before initialization, make sure that both PC IP, and device IP are in the same network segment, otherwise it might fail to enter initialization page.

Step 1 Set IP address, subnet mask, and gateway of PC, and device respectively.



- If there is no router in the network, distribute IP address of the same segment.
- If there is router in the network, configure the corresponding gateway, and subnet mask.

The IP address is 192.168.1.108 by default.

Step 2 Use ping `***.***.***.***` (device IP address) command to check whether network is connected.

Step 3 Open browser, enter the IP address of the Camera in the address bar, and then press the Enter key.

Figure 4-1 Device Initialization

Device Initialization

Username admin

Password

The minimum pass phrase length is 8 characters

Weak Middle Strong

Confirm Password

Use a password that has 8 to 32 characters, it can be a combination of letter(s), number(s) and symbol(s) with at least two kinds of them.(please do not use special symbols like ' " ; : &)

Email Address

To reset password, please input properly or update in time.

Confirm

Step 4 Enter Password, and Confirm Password.



- The new password must consist of 8 to 32 characters, and contain at least two types from upper case, lower case, number, and special characters (excluding ' " ; : &).
- If you want to change your password again, go to **Setting > System > Account > Account**.

Step 5 Select the **Email Address** check box, and then enter your email address (recommended to set for resetting your password).

Step 6 Click **Confirm**.

Step 7 On the **Online Upgrade** page, click **Confirm**.

Figure 4-2 Config guide

Config Guide

IP Address 192 .

Subnet Mask 255 .

Default Gateway 192 .

Finish

Step 8 Change the default IP address, subnet mask, and default gateway, and then click **Finish**.

Figure 4-3 Login



Step 9 Enter the username, and password, and then click **Login**.



Prompt box will pop out when username or password is incorrect, see Figure 4-4, and it will remind you of remaining attempts. The account will be locked for 300 s if user enters incorrect username or password for 5 times consecutively. See Figure 4-5.

Figure 4-4 Login error

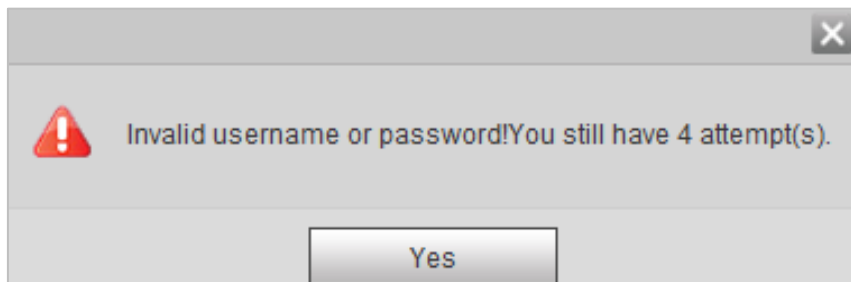
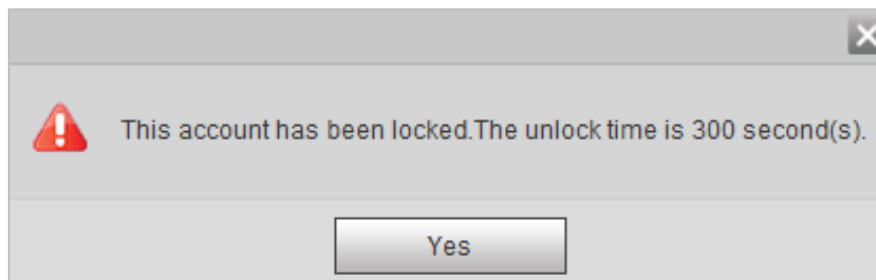

Figure 4-5 Account locked



Step 10 Click **Please click here to download**, and install the plug-in in the video window. The system automatically downloads webplugin.exe, and installs it according to prompt.



Before installing plug-in, make sure that the associated plug-in option of active has been modified as **Enable** or **Prompt** in **Internet Option > Security Settings**.

Figure 4-6 Web page

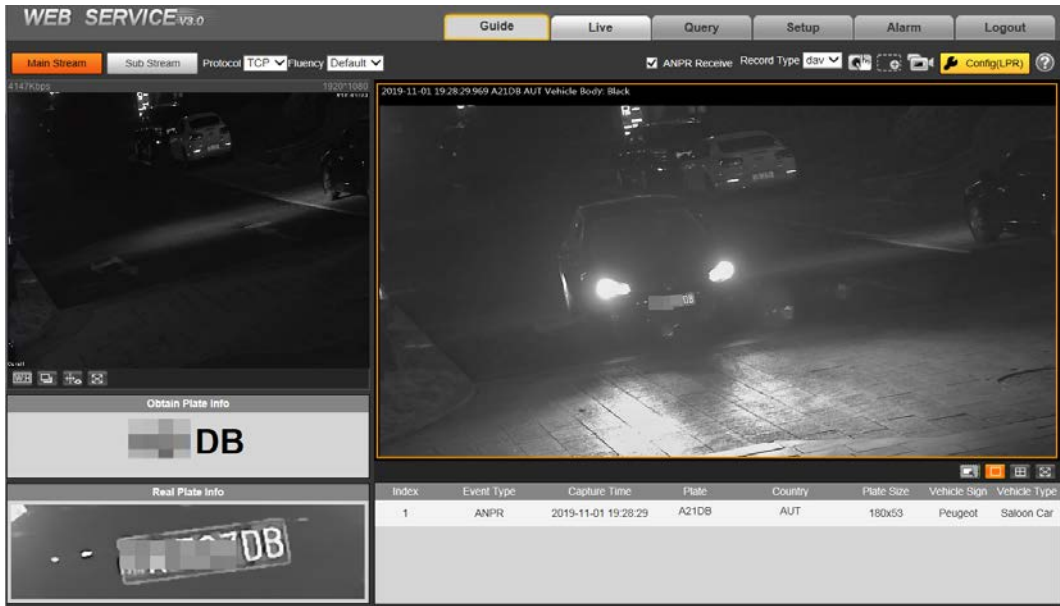

It will pop out the prompt box of authorization failed when there is no operation on the web page for a long time. In this case, you need to log in again.

Figure 4-7 Prompt

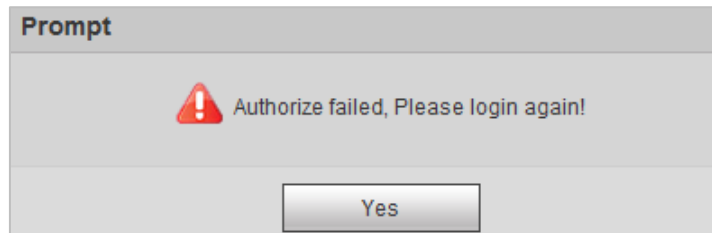

4.1.3 Login

- Step 1 You can log in to the web page by following the steps below. For first-time login or logging in after restoring factory default Settings, see "4.1.2 Device Initialization".
- Step 2 Enter the IP address of the Camera in the browser address bar, and press Enter.
- Step 3 Enter your login username, and password, and then click **Login**.



- A box pops up when the username or password is incorrect.
- If you enter invalid user name or password for five times, the account will be locked for 300 s.

Figure 4-8 Invalid username or password

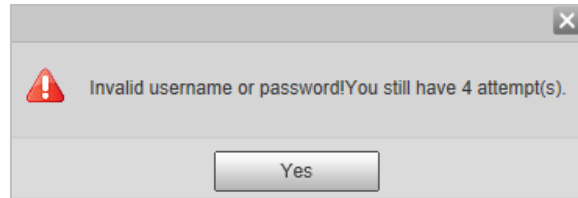

4.1.4 Resetting Password

When you forgot your password, you can configure new password through the password reset function.



- When scanning QR code to acquire security code, one QR code supports security code acquisition up to twice.
- After receiving security code by email, you need to reset password within 24 hours, otherwise, the security code will be invalid.
- One device can generate security code up to 10 times in one day, so the Camera can be reset up to 10 times in one day.
- Email address must be filled in during device initialization; otherwise it will fail to send you the security code, and you will not be able to reset your password. Email address of admin can be modified from **Setting > System > Account > Account**.

Step 1 Open the browser, enter the IP address of the Camera in the browser address bar, and then press Enter.

Figure 4-9 Login page

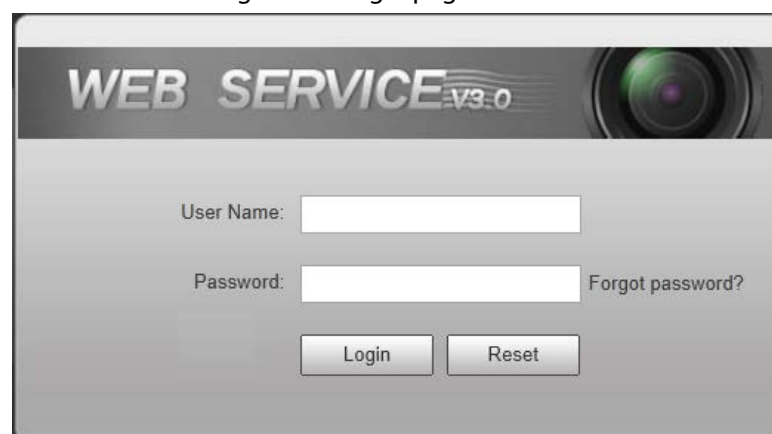

Step 2 Click **Forgot password?**

Figure 4-10 Information

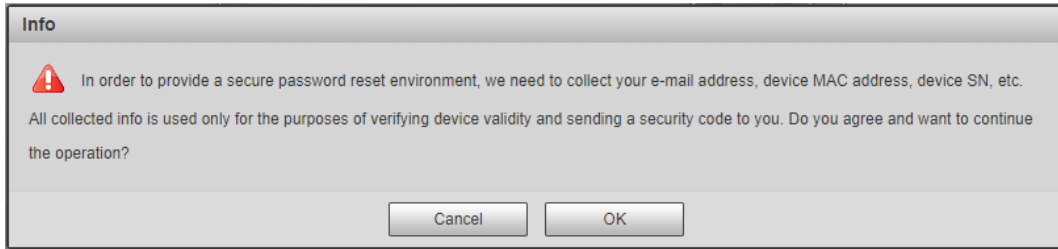

Step 3 Click **OK**.



If you use IE browser, the system might prompt **Stop running the script**, click **No**, and continue to run the script.

Step 4 Scan the QR code according to the page prompt, and send the scanning result to designated email, and acquire security code.



Scan the actual QR code. Do not scan the QR code in this manual.

Figure 4-11 Reset password (1)

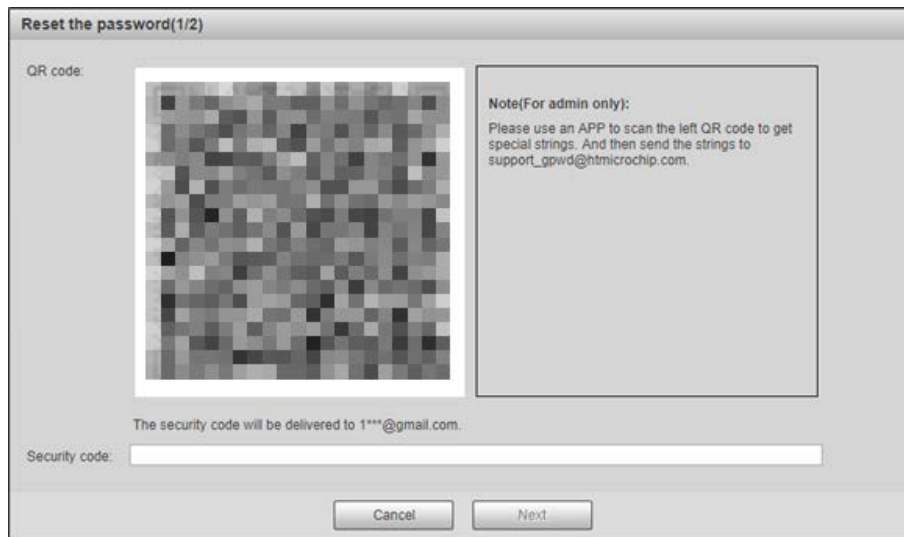

Step 5 Enter received security code in the text box of **Security code**.

Step 6 Click **Next**.

Figure 4-12 Reset password (2)

Step 7 Set **Password**, and enter your new password again in **Confirm Password**.

- The new password must consist of 8 to 32 characters, and contain at least two types from upper cases, lower cases, numbers, and special characters (excluding ' " ; , and &).
- The new password must be the same as the **Confirm Password**. Follow the password security notice to set a high security level password.

Step 8 Click **OK**.

4.1.5 Web Functions

This section mainly introduces the following 6 functions on the web page.

Figure 4-13 Tab





Table 4-2 Tab function description

Tab	Function
Guide	Quick configuration of plate pixel, recognition region, and more.
Live	View, and record live video, and image, adjust video, and image window, set client image parameter, and so on.
Query	Search for different types of pictures, and videos, and configure watermark verification of videos.
Setting	Set rules of intelligent traffic, camera basic attribute, network, event, storage, and system, and view system information.
Alarm	Set alarm prompt.
Logout	Log out web.

The following buttons are very common on the web page.

Table 4-3 Common buttons description

Button	Description
	Restore all parameters to system defaults.

Button	Description
	Recover the parameters to the value last saved.
	Save the settings.

4.2 Guide

On the **Guide** page, you can configure capture scenarios, and get assistance with setting installation scenario.



You can click  at the upper-right corner of **Guide** page to exit.

Step 1 Click the **Guide** tab.

Figure 4-14 Confirmation

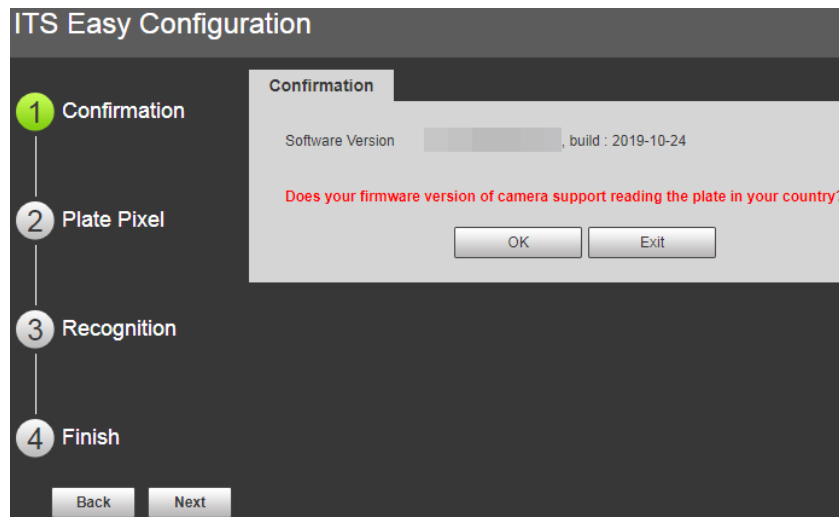

Step 2 Confirm **Software Version**, and then click **OK**.

Figure 4-15 Plate pixel

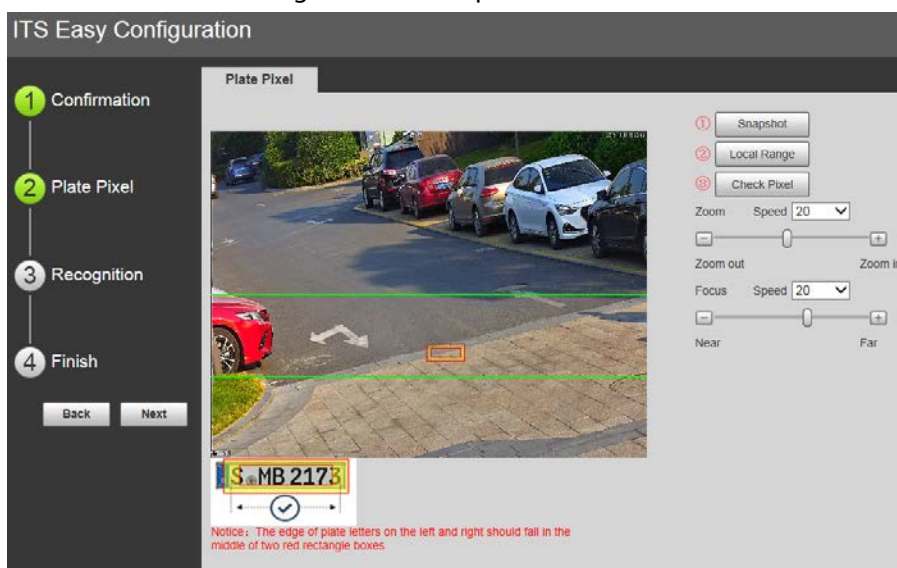

Step 3 You can check whether the video image is properly zoomed, and focused by checking the plate pixel.

1) Drag zoom, and focus bar to adjust the video image properly.

- 2) When the vehicle plate comes into the green line area, click **Snapshot** to take a snapshot of the plate.
Snapshot becomes **Resume**.
- 3) Drag the yellow plate pixel box to the position of the plate.
- 4) Click **Zoom**.
Zoom in the picture selected by the plate pixel box. It can realize 2x or 4x zoom rate.
- 5) Adjust the position of plate pixel box, and make it the optimal plate size.



If the plate within the yellow box is larger than the optimal plate size in the example, zoom out the video image; if smaller, zoom in the video image.

Figure 4-16 Plate pixel size



- 6) Click **Check Pixel**.

Figure 4-17 Check plate

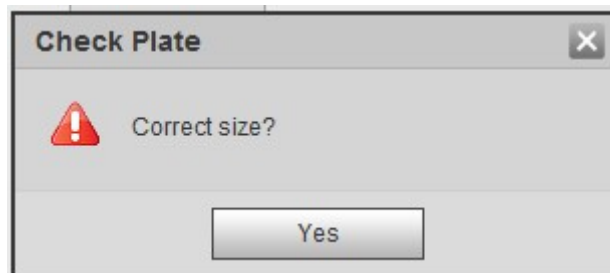

- 7) Click **Yes**, and plate pixel configuration is finished.

Figure 4-18 Recognition

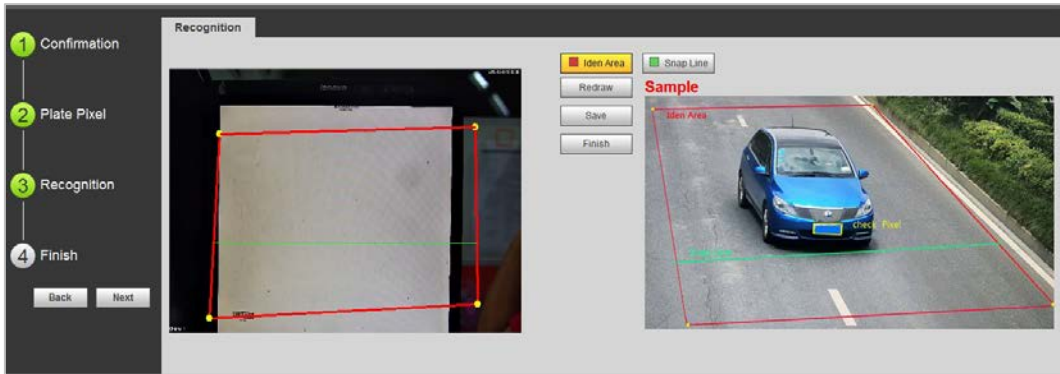

Step 4 Configure recognition area.

The configuration example on the right of video page can be used as a reference.

1) Click **Ident Area**(identification area).

Click, and draw 4 lines on the video page, and the recognition area is formed.

2) Click **Snap Line**.

Draw snap line by dragging mouse on the area. The snap line must cross the area.

3) Click **Save** to complete the Settings.

Step 5 Click **Finish**, exit **Guide** page, and enter **Live** page.

4.3 Live

Click the **Live** tab.

On this page, it can realize several functions such as live video, live picture, real-time capture, record, and config (LPR), and more.

Figure 4-19 Live

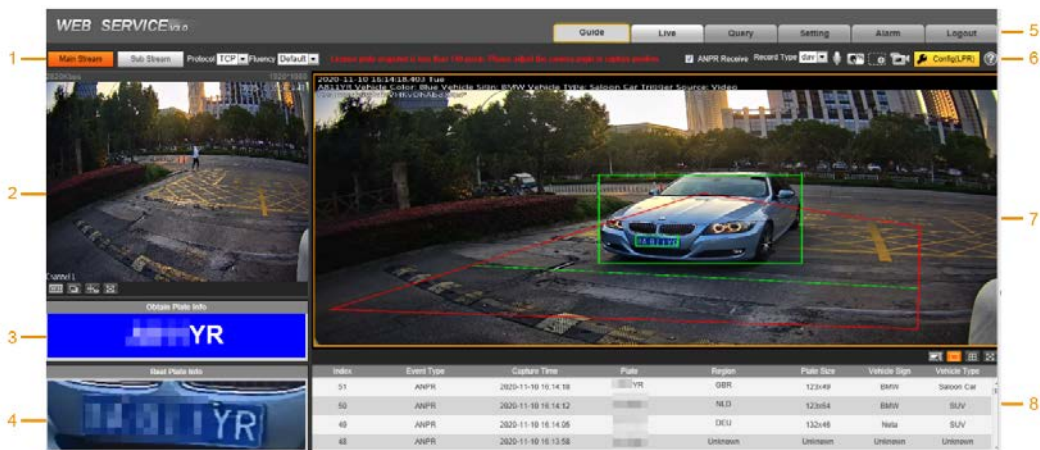

Table 4-4 Live page bar

No.	Description	No.	Description
1	Video stream	5	System functions
2	Live view	6	Functions of Live page
3	Logged plate number	7	Vehicle snapshot
4	Plate snapshot	8	Event list

4.3.1 Video Stream

- **Main Stream:** Make sure that the Camera can record video, and carry out network surveillance when the network is normal. You can configure main stream resolution within the supported range of the Camera.
- **Sub Stream:** Replaces main stream to make network surveillance, and reduce the network bandwidth possession when network bandwidth is insufficient.
- **Protocol:** Video surveillance protocol, currently it only supports TCP.
- **Fluency:** Fluency of viewing the live video. The fluency can be set to **High, Middle, Low,** and **Default** (recommended).

4.3.2 Live View

Displays the live video captured by the Camera. You can also click the icons to change the display mode of live view.



- : Adjust the image to original size or appropriate window.
- : Click it to switch to big window, and click  on the lower-left corner to display image adjustment window. Click it again to exit big window.

Figure 4-20 Big window







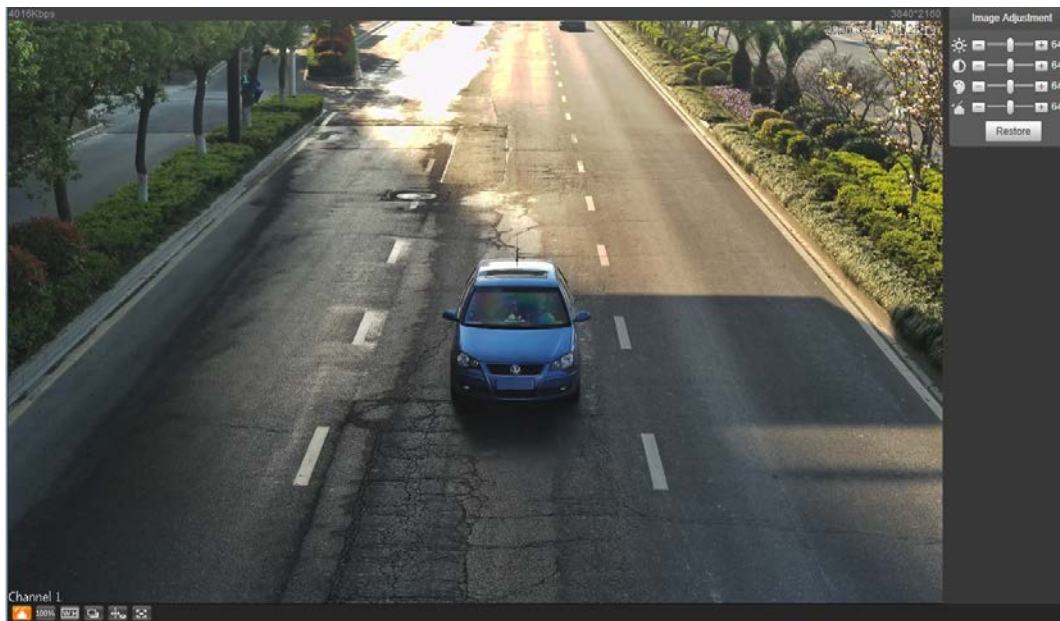

- : Click it to enable smart track detection. Number plate, vehicle bounding box, and other smart tracking information will be displayed in the video image.
- : Click it, and the window is displayed in full screen; double-click or right-click to exit full screen.

Table 4-5 Image adjustment description

Icon	Name	Description
	Brightness	Adjust the overall image brightness. Change the value when the image is too bright or too dark. The range is from 0 to 128 (64 by default).

Icon	Name	Description
	Contrast	Change the value when the image brightness is proper but contrast is not enough. The range is from 0 to 128 (64 by default).
	Hue	Adjust the image hue. For example, change red into blue. The default value is made by the light sensor, and normally it does not have to be adjusted. The range is from 0 to 128 (64 by default).
	Saturation	Adjust the color vividness, and will not influence the image overall brightness. The range is from 0 to 128 (64 by default).
	—	Restore brightness, contrast, saturation, and hue to default values.



In this image adjustment window, you can only adjust image brightness, contrast, hue, and saturation of local web. To adjust system brightness, contrast, hue, and saturation, go to **Setting > Camera > Attribute > General**.

4.3.3 Logged Plate Number

Displays the plate number recognized by the Camera in real-time when a vehicle passes.

4.3.4 Plate Snapshot

Displays the snapshot of license plate when a vehicle passes.

4.3.5 System Functions

Click the icons to set system functions, which include playback, video recording, and snapshot query, intelligent rules setting, alarm event setting, and system logout. See more details in the following chapters.











4.3.6 Functions of the Live Page

This section introduces operations such as image, and video capture, zoom, record, and talk.

Figure 4-21 General function option column

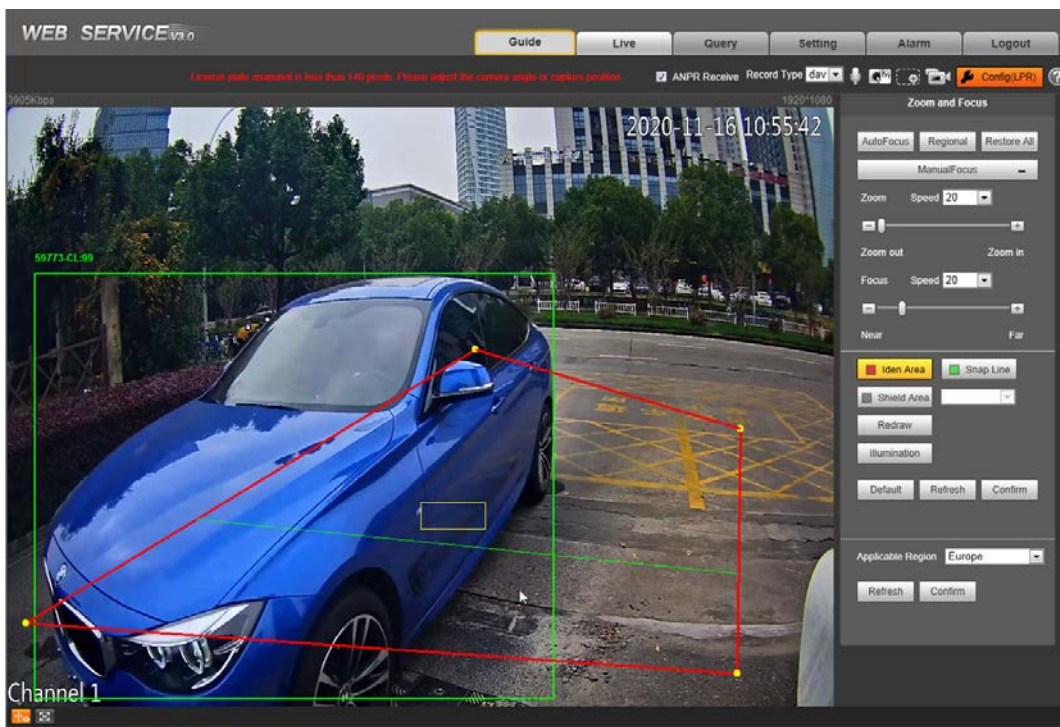

Table 4-6 General function description

Icons	Name	Description
	ANPR Receive	Select the check box, and the Camera automatically receives vehicle snapshots, and detects event information triggered by sources such as radar or video detection, and displays such snapshots, and information at the lower part of the page. The snapshots are saved in the storage path defined by Setting > Storage > Destination > Save Path .
	Record Type	Select the format of video recordings (dav by default).
	Talk	Click Talk , and you can communicate with people on site through the camera.
	Manual Snapshot	Click to take a snapshot when a vehicle passes. The snapshot is saved in the storage path.  <ul style="list-style-type: none"> • Enable ANPR Receive first. • To change the storage path of snapshots, go to Setting > Storage > Destination > Save Path.
	Digital Zoom	Drag to select any area in the video window, and then the area will be zoomed in. In any area of the video window, click  or right-click to exit.
	Video Recording	Click it to start recording. Click  again to stop recording. You can set the storage path of video recordings from Setting > Storage > Destination > Save Path .
	Config (LPR)	You can draw the area of plate detection, adjust camera's focal length, and set applicable region.

Click .





Figure 4-22 Config (LPR)



The steps of config (LPR) are shown as follows.

Step 1 Set focus, and zoom mode, which is used to recognize vehicle.

Table 4-7 Focus parameter description

Parameter	Description
Auto Focus	Auto adjust camera lens, and make the scenario clearly focused.
Regional	Click Regional , and then draw a box in the video image to focus the defined region in the box.
Manual Focus	<ul style="list-style-type: none"> • Zoom: <ul style="list-style-type: none"> ◇ Speed: There are totally 3 levels to be selected. ◇ Zoom in, zoom out: Click  to zoom in, click  to zoom out; Or directly drag adjustment bar, and set zoom. • Focus: <ul style="list-style-type: none"> ◇ Speed: There are totally 3 levels to be selected. ◇ Near, far: Click  to focus on far place, click  to focus on near place. You can also directly drag adjustment bar to set near, and far focal length.
Restore All	Restore all to initialized settings.

Step 2 Select, and draw the config line type.



The configured area line, and detection line in **Guide** are displayed in the video page.

Table 4-8 Line parameters description

Parameter	Description
Iden Area	Click it, and draw the area range which needs to be detected. The recognition area line is displayed as red box.
Snap Line	Draw the detection line which triggers video capture, it is as functional as the line in traffic. It will trigger, and take snapshot when the vehicle crosses the detection line. Snap line is displayed as green line.
Shield Area	Set the area range which needs to be shielded. LPR is not implemented within the shielded area. It supports setting max two shielded areas. Area line is displayed as gray box.

Step 3 Draw lines on the view page.

Click **Redraw** to delete lines one by one.

Step 4 Click **Confirm** to save the drawn lines.

Step 5 Select **Applicable Region** from **Russian-Speaking Region** and **Europe**. System restarts after changing the region and all the functions such as plate recognition, alarm trigger and more apply to the selected area.

Step 6 Click **Confirm**.

4.3.7 Vehicle Snapshot

Select **ANPR Receive**, and then snapshots will be displayed when vehicles pass.

4.3.8 Event List

Select **ANPR Receive**, and the event information will be displayed, including No., event types, capture time, lanes, plates, vehicle color, speed, vehicle signs, and vehicle types.

4.4 Query

Click the **Query** tab, and the system displays query page where you can search for pictures, and video recordings.

4.4.1 Image Search

4.4.1.1 SD Picture

Search conditions can be set in this section. You can search for event, and plate information of the SD card within the period.

Step 1 Select **Query > Image Search > SD Card Image**.

Figure 4-23 SD Picture

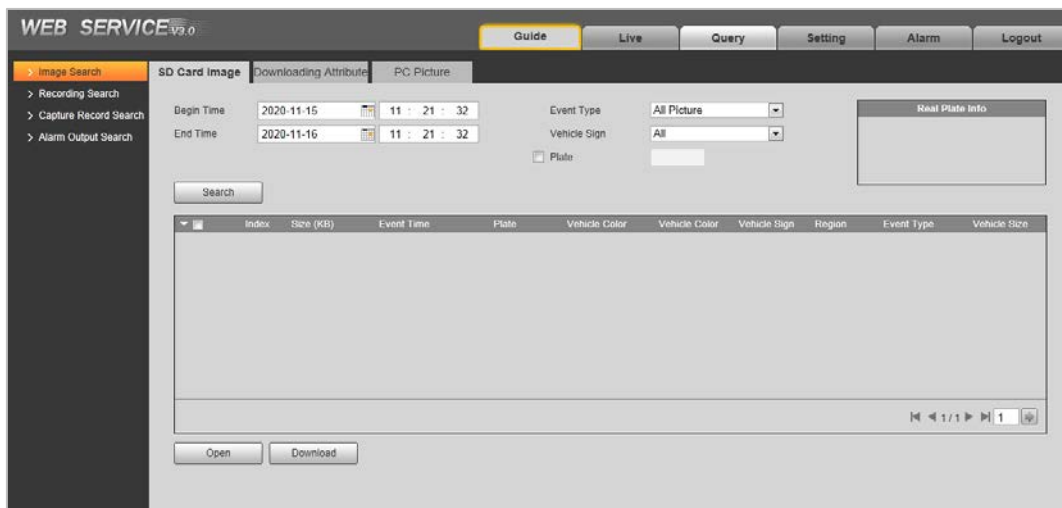

Step 2 Configure the parameters as needed.

Table 4-9 SD picture parameter description

Parameter	Description
Begin Time	Set the period of Image Search.
End Time	
Event Type	Search for all pictures, or search for pictures which conform to requirements according to filtering condition based on violation type.
Vehicle Sign	Take vehicle sign as query condition, then it can select one or all.
Plate	Select the Plate check box, take plate feature as query condition, and then inquire the pictures which conform to requirements. You can also set some parameters of the plate to realize fuzzy query of plate number.

- Step 3** Click **Search**, and it displays all the picture file lists which conform to query condition in the file list.
Click some line in the list, and the plate picture information will be displayed in **Real Plate Info**.
- Step 4** Download picture.
Click to select pictures, and then click **Download**.
- Step 5** Set the storage path of picture in the prompted window. The system starts to download the pictures to local PC.

4.4.1.2 Image Downloading Attribute

In this section, you can set the picture download time, and mode. Confirm picture name according to **Help**.

- Step 1** Select **Query > Image Search > Downloading Attribute**.

Figure 4-24 Download attribute

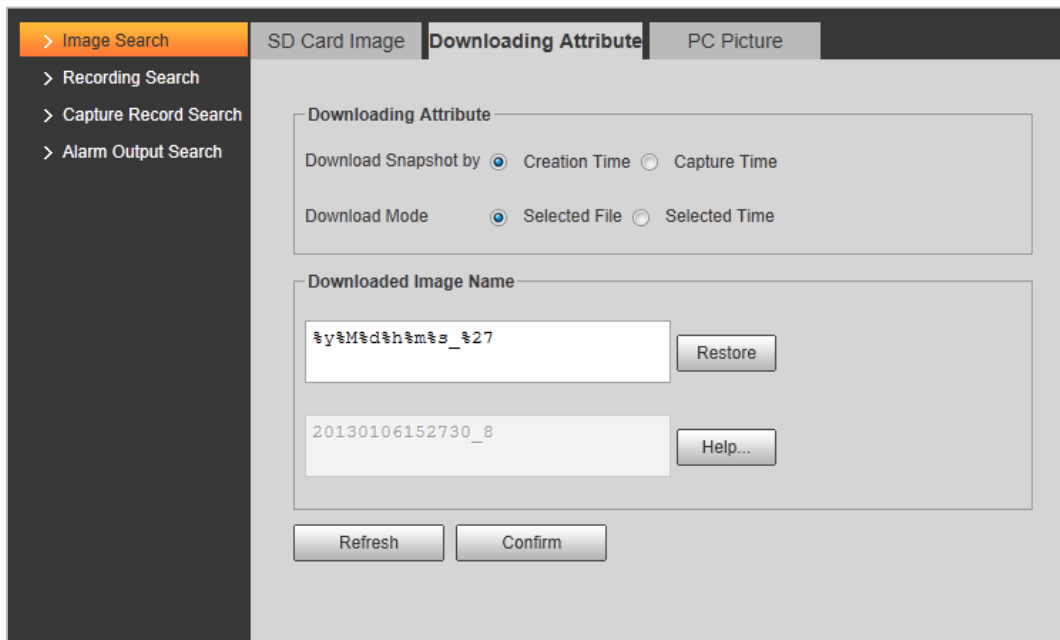

- Step 2** Configure the download parameters.

Table 4-10 Download attribute parameters description

Parameter	Description
Download Snapshot by	<ul style="list-style-type: none"> • Creation Time: When you download snapshot on PC, the downloading time in image attribute is snapshot storage time. • Capture Time: When you download snapshot on PC, the downloading time in image attribute is snapshot capture time.
Download Mode	<ul style="list-style-type: none"> • Selected File: Select the needed picture (It supports selecting single picture or several pictures at the same time), click Download, and the system will pop out the save dialog box. • Selected Time: Click Download, and the system will automatically download all the pictures within the defined time.
Restore	Restore the picture name to default.
Help...	View the naming rule of downloaded pictures.

Step 3 Click **Confirm**.

4.4.1.3 PC Picture

The section introduces the way of checking whether the watermark of PC picture is tampered.

Step 1 Select **Query > Image Search > PC Picture**.

Figure 4-25 PC picture

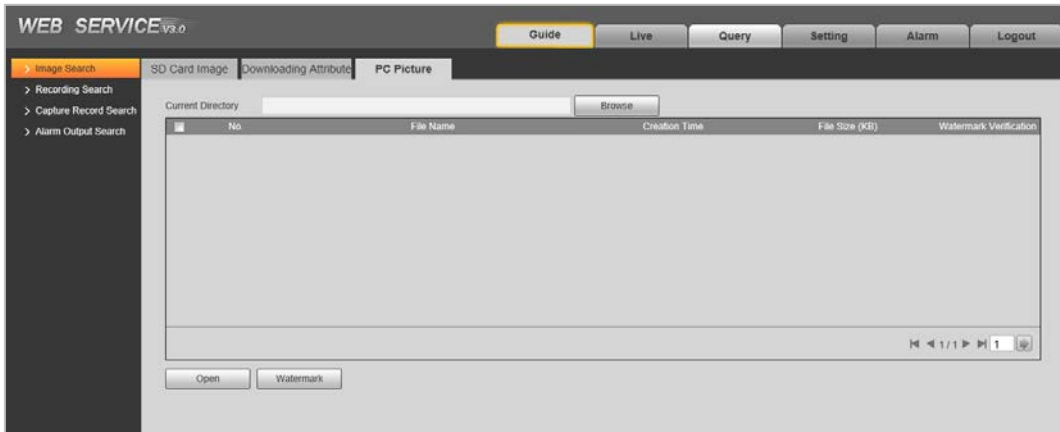

Step 2 Click **Browse**, and select the folder where the verified picture is located.

Step 3 Select the picture which needs to be verified.

Step 4 Click **Watermark**, and view result in the picture list.

Click **Open** or double-click the picture if you need to preview the picture.

4.4.2 Recording Search

4.4.2.1 Record

You can set video play of local PC on this page.





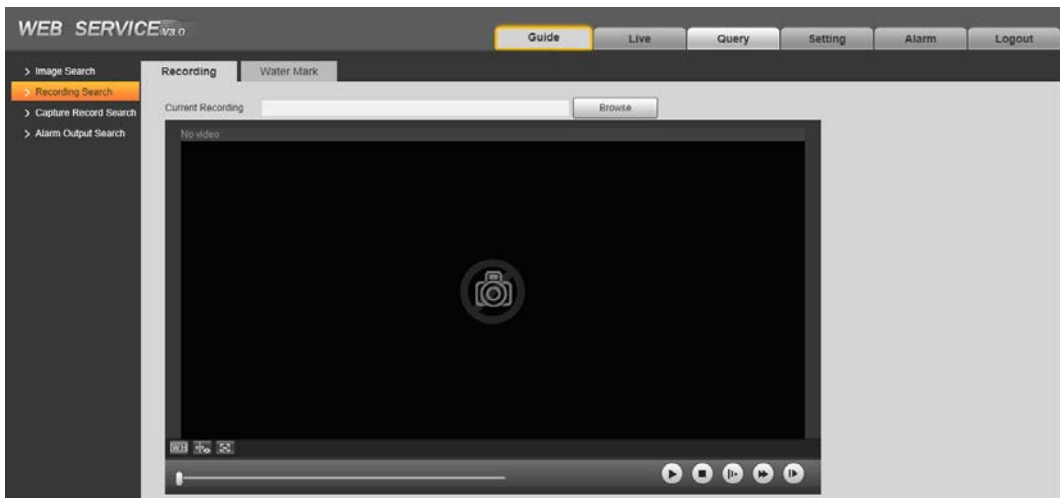

Step 1 Select **Query > Recording Search > Recording**.

Figure 4-26 Record



Step 2 Click **Browse**, select record path, click **Open**, and view the video.

Table 4-11 Play function description

Icon	Description
	<ul style="list-style-type: none">  : Play video.  : Pause.
	Stop playing video.
	Slow down video playing.
	Speed up video playing.
	Skip to the next frame.

4.4.2.2 Watermark

You can verify whether the watermark of local record is tampered.



Go to **Setting > Camera > Video > Video**, and select **Watermark Settings** to enable the function, and set the corresponding **Watermark Character**. The default character is DigitalCCTV.

Step 1 Select **Query > Recording Search > Water Mark**.

Figure 4-27 Watermark

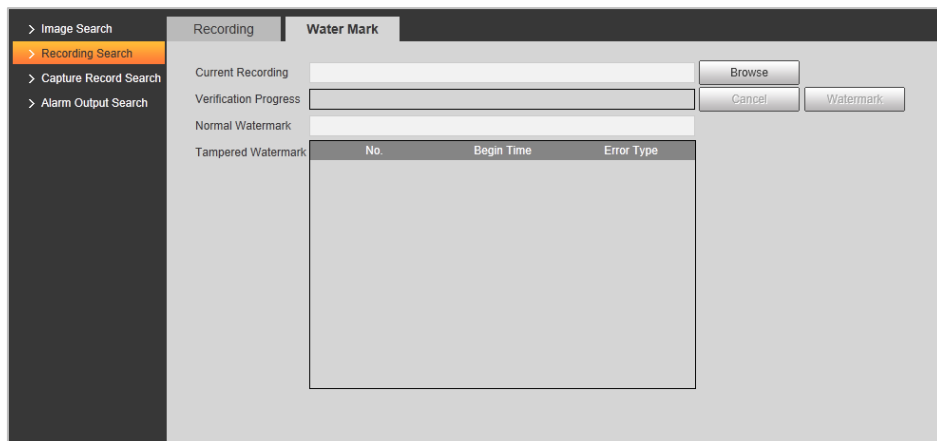

Step 2 Click **Browse**, and select a file that you want to verify.

Step 3 Click **Watermark**, and the system displays verify progress, normal watermark, and some other information.

The page of **Watermark Verification Completed** appears after verification.

4.4.3 Capture Record Search

Search for the vehicle record within the defined period, and according to the defined direction.



- It supports max 10,000 records or 1,024 records respectively when the Camera is installed with or without TF card.
- If the passing vehicle records are unreadable in Excel after being imported, change them into UTF-8 encoding document in txt, and then they can be opened normally.

Step 1 Select **Query > Capture Record Search**.

Step 2 Set **Begin Time**, and **End Time**, and then set the **Direction** (vehicle movement direction,

including **Approaching**, **Departing**, and **Unknown**).

Step 3 Click **Search** to search for the plates that meet the search conditions.

Figure 4-28 Capture record search

Index	Event Time	Region	Plate	Vehicle Direction	Allowlist	Blocklist	Direction
-------	------------	--------	-------	-------------------	-----------	-----------	-----------

Step 4 Click **Export**, and then select storage path to export the results to PC.

4.4.4 Alarm Output Search

Set the search conditions to search alarm output.



Make sure that all the external devices are connected with the Camera through RS-485 port.

Step 1 Select **Query > Alarm Output Search**.

Step 2 Set the start time and end Time.

Step 3 Click **Search**.

Figure 4-29 Alarm output search

Index	Event Time	Signal Source	Alarm Type	Alarm Output	Plate	Time Consumed
1	2020-11-09 19:39:12	10.34.4.45	Manually Open Barrier (Web)	1	None	0
2	2020-11-09 19:39:32	10.34.4.45	Manually Open Barrier (Web)	1	None	0
3	2020-11-09 19:39:38	10.34.4.45	Manually Open Barrier (Web)	1	None	0
4	2020-11-09 19:44:24	10.34.4.45	Manually Open Barrier (Web)	1	None	0



Click **Export** can export the search results to local.

4.5 Setting

You can configure several parameters such as ITC, camera, network, event, storage, system, and system information.

4.5.1 ITC

You can set intelligent parameters of the Camera.

4.5.1.1 Detection

4.5.1.1.1 Snapshot

You can set snapshot rule of the Camera.

Step 1 Select **Setting > ITC > Detection > Snapshot**.

Figure 4-30 Snapshot

The screenshot displays a configuration window for the Snapshot feature. At the top, 'Work Mode' is set to 'Video'. Under 'ANPR Parameters', 'Number of Snapshots' is 1 (range 1-2) and 'Capture Direction' is 'Two-way' (selected). The 'Video Mode Parameters' section includes 'Scene' set to 'Small Vehicle', 'Licensed Vehicle' Frame Threshold at 1 (range 1-3), and 'Unlicensed Vehicle' Frame Threshold at 10 (range 10-30). The 'Loop Mode Parameters' section shows 'Max Pass Time' at 5 seconds and 'Loop Cache Frame' at 3 (range 3-30). At the bottom, there are 'Default', 'Refresh', and 'Confirm' buttons.

Step 2 Configure the parameters.

Table 4-12 Description of capture parameters

Parameter	Description
Work Mode	<ul style="list-style-type: none"> • Loop: Use loop to take snapshots. • Video: Use video to take snapshots. • Mixmode: Use loop and video to take snapshots.
Number of Snapshots	It can take 1–2 snapshot(s).
Capture Direction	<ul style="list-style-type: none"> • Approaching: Only captures vehicles that approach. • Departing: Only captures vehicles that depart. • Two-way: Captures vehicles that approach or depart.
Video Mode Parameters	<ul style="list-style-type: none"> • Scene: Select Small Vehicle or Large Vehicle as needed. • Licensed Vehicle Frame Threshold: Configure the frame number of capturing licensed vehicle. 1 (default) means to capture when detecting one frame of licensed vehicle passing detection area. • Unlicensed Vehicle Frame Threshold: Configure the frame number of capturing unlicensed vehicle. 10 (default) means to capture when detecting 10 frames of unlicensed vehicle passing detection area.
Loop Mode Parameters	<ul style="list-style-type: none"> • Max Pass Time: Configure the maximum time for vehicle passing. 5 s (default) means that under loop mode, the capture will not take snapshots when both loops are triggered within 5 s interval. • Loop Cache Frame: Configure the cache frame number of loop. 3 (default) means to save 3 frames of loop detection result.

Step 3 Click **Confirm**.

4.5.1.1.2 IO

You can configure loop IO snapshot parameters.



Step 1 Select **Setting > ITC > Snapshot Settings > IO**.

Step 2 Select **Loop I/O** check box.

Figure 4-31 IO

Step 3 Configure parameters.

Table 4-13 Loop I/O parameters

Parameter		Description
Trigger Mode Config	IO	Only Loop I/O can be selected.
	Loop 1	Set the loop trigger mode.
	Loop 2	<ul style="list-style-type: none"> • Not triggered: No capture is triggered. • Rise Edge: Capture is triggered when the vehicle enters loop. • Fall Edge: Capture is triggered when the vehicle exits loop.  <p>When the scheme is single_in1-snap, then loop 2 can not be set.</p>
IO Config	Scheme	<ul style="list-style-type: none"> • Set IO snapshot scheme. • Single_in_1: Lay single loop, and it will take a snapshot when the vehicle enters a loop. • Double_in_1: Lay double loops, and it will take a snapshot when the vehicle enters the first loop. • Double_in_2: Lay double loops, and it will take a snapshot when the vehicle enters the second loop.
	Loop Mapping	<p>Select the corresponding relationship between logical loop and physical loop.</p>  <ul style="list-style-type: none"> • When the scheme is single_in_1, only need to select the physical loop corresponds to logical loop 1. • You need to configure this in mix mode.

Step 4 Click **Confirm**.

4.5.1.2 Intelligence

4.5.1.2.1 Recognition

You can set vehicle recognition parameter, recognition mode, and some other functions.

Step 1 Select **Setting > ITC > Intelligence > Intelligent Analysis > Recognition**.

Figure 4-32 Recognition

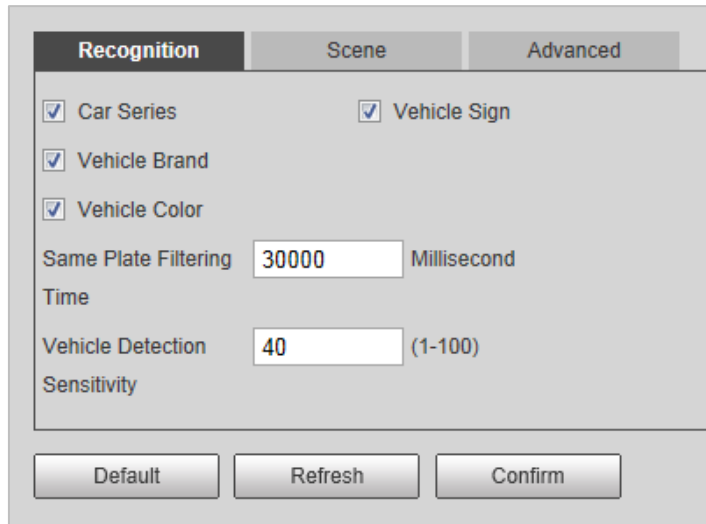

Step 2 Configure parameters.

Table 4-14 Recognition parameters description

Parameter	Description
Car Series	Select the target of recognition according to your requirements.  Overseas car series not supported.
Vehicle Sign	
Vehicle Brand	
Vehicle Color	
Same Plate Filtering Time	One plate can be captured once within the defined period.
Vehicle Detection Sensitivity	Set the sensitivity of vehicle detection. The higher the value, the more sensitive the detection.

Step 3 Click **Confirm**.

4.5.1.2.2 Scene

You can configure the advanced functions of plate recognition, and customize special functions.

Step 1 Select **Setting > ITC > Intelligence > Intelligent Analysis > Scene**.

Figure 4-33 Scene

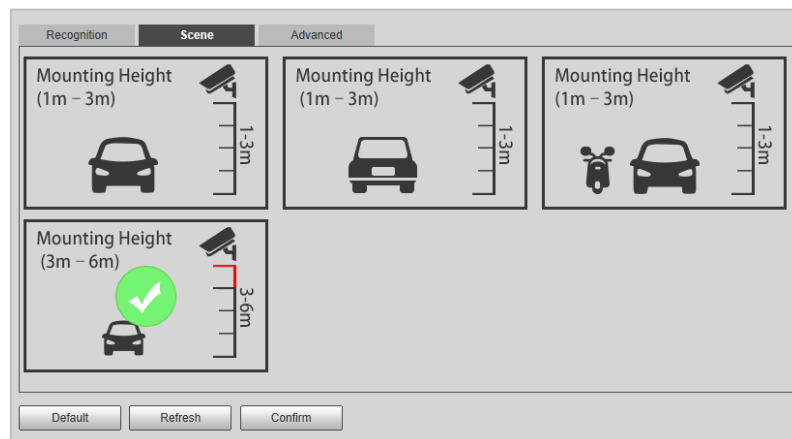

Step 2 Select detection scene as needed.

- Head first: Higher recognition sensitivity towards plate on head.
- Tail first: Higher recognition sensitivity towards plate on tail.
- Bicycle (electric bicycle or motorcycle): Higher recognition sensitivity towards electric bicycle or motorcycle plate.
- Mounting height: Higher recognition sensitivity when the Camera is installed on higher place.

Step 3 Click **Confirm**.

4.5.1.2.3 Advance Configuration

You can configure advanced vehicle recognition function through algorithm.

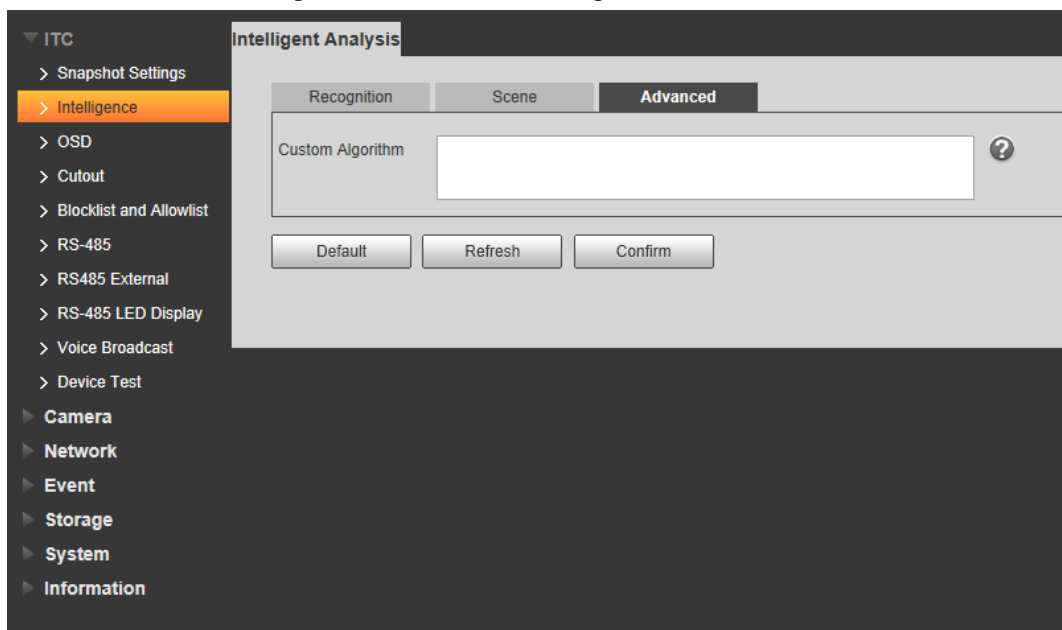

Step 1 Select **Setting > ITC > Intelligence > Intelligent Analysis > Advanced**.

Figure 4-34 Advanced configuration



Step 2 Configure parameters.

Table 4-15 Advanced configuration parameter description

Parameter	Description
Custom Algorithm	Enter custom algorithm for advanced function.
	Click  to view advanced algorithm formula.

4.5.1.3 OSD Configuration

Set the overlapping OSD (On-screen Display) information on video and image.

4.5.1.3.1 Video OSD

Set OSD information of video channel.

Step 1 Select **Setting > ITC > OSD > Video OSD**.

Figure 4-35 Video OSD

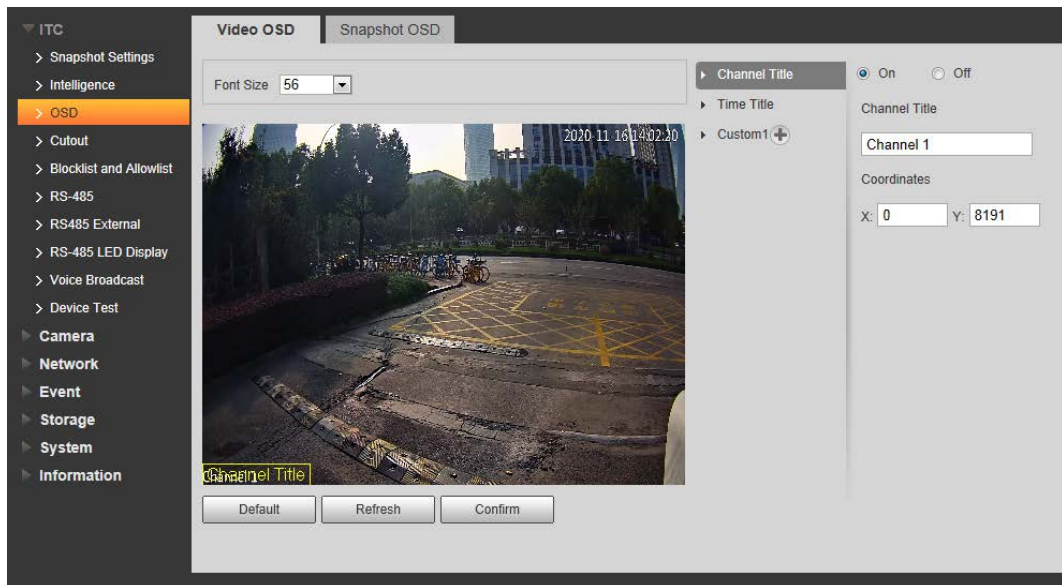

Step 2 Select font size.

Step 3 Set channel title, and coordinates.

- 1) Click **Channel Title**.
- 2) Select **On**.
- 3) Enter channel name.
- 4) Drag the yellow box or enter coordinate directly to set the location of channel title.

Step 4 Set time title, and location.

Figure 4-36 Time title

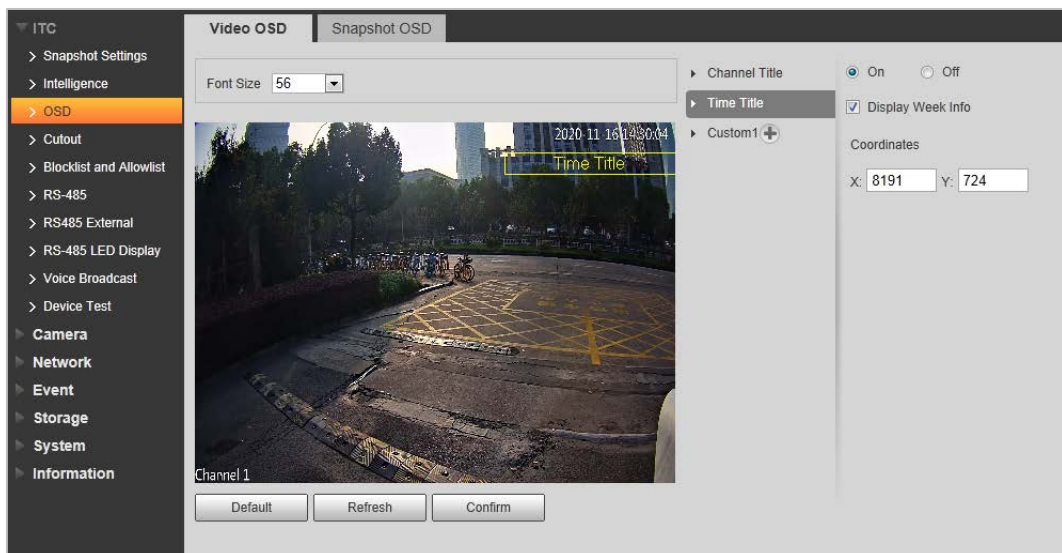

- 1) Click **Time Title**.
- 2) Select **On**, and check **Display Week Info**.
- 3) Drag the yellow box or enter coordinate directly to set the location of time title.

Step 5 Click **Custom1** , select **On**, and then set OSD information, and its display location according to requirement.

Figure 4-37 Custom



The system supports up to 6 customized regions.

Step 6 Click **Confirm**.

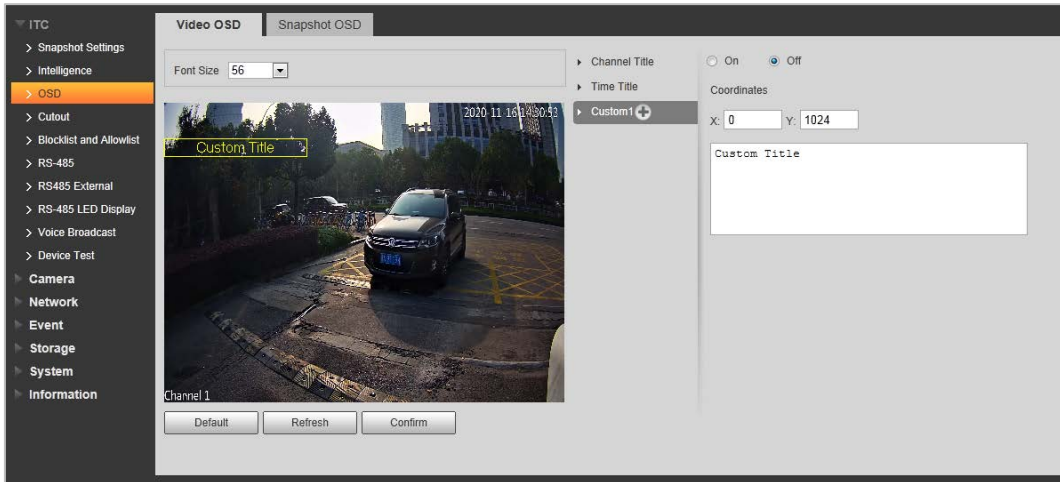
4.5.1.3.2 Snap OSD

You can set OSD information of pictures.

Step 1 Select **Setting > ITC > OSD > Snapshot OSD**.

Figure 4-38 Snap OSD

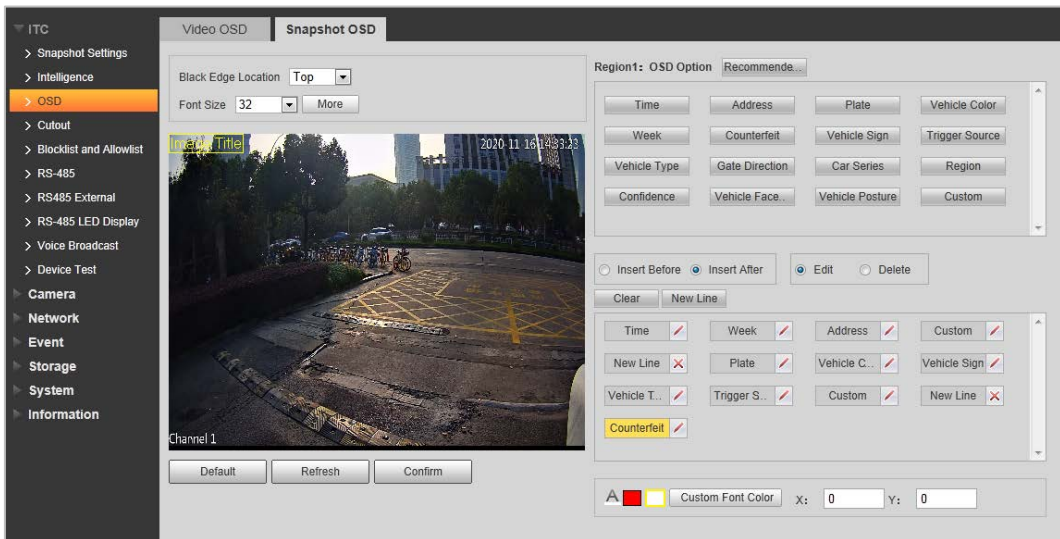

Step 2 Move the title box to displayed location, or manually enter coordinate value into the X/Y box in the lower-right corner of the page.

Step 3 Select **Black Edge Location**, and then you can set the position of the OSD black strip. You can select from **Top**, **Bottom**, and **None**.

Step 4 Set font size of OSD information. You can set font color of picture OSD information in



Step 5 Click **More**.

Figure 4-39 New line, and OSD separator







Step 6 Select the **NewLine** check box as needed, and then set separator types of OSD information.

You can manually enter other separators when selecting **Custom** from **Osd Separator**.

Step 7 Set OSD options.

Table 4-16 Snap OSD parameters description

Parameter	Description
Insert Before	Select one OSD option, click Insert Before , and select other OSD options. The new OSD options will be displayed before original OSD option.
Insert After	Select one OSD option, click Insert After , and select other OSD options. The new OSD option will be displayed after the original OSD option.
Edit	Click it, and all the OSD information status is displayed as  except New Line . Click  to modify the prefix, suffix, content, and separator of corresponding OSD option.
Delete	Click it, and all the selected OSD information status is displayed as  , click  to delete corresponding OSD option.
Clear	Delete all the OSD information.
New Line	After selecting some OSD information, click New Line , and the OSD information inserted after NewLine will be displayed in a new line on the picture.

Step 8 Click **Confirm**.

4.5.1.4 Cutout Configuration

4.5.1.4.1 Snapshot Cutout

Enable plate cutout function, and the system will cut out the recognized plate picture, and save it to the storage path.

Step 1 Select **Setting > ITC > Cutout**.

Figure 4-40 Snap cutout

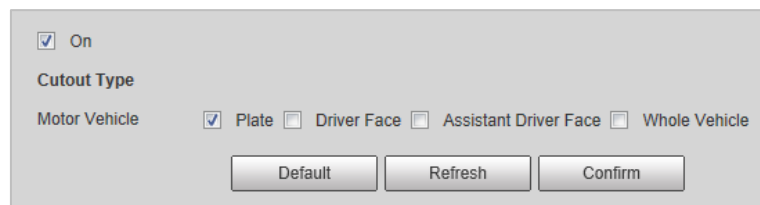

Step 2 Select **On**, and select **Plate** or **Whole Vehicle**, and then the function of plate cutout or whole vehicle cutout is enabled.

Step 3 Click **Confirm**.

4.5.1.4.2 Face Overlap

In this section, you can select whether to overlap the face image of the driver and assistant driver onto the snapshot, and the overlap position and size.

Step 1 Select **Setting > ITC > Cutout > Face Overlap**.

Step 2 Configure the parameters as needed.

Figure 4-41 Face overlap

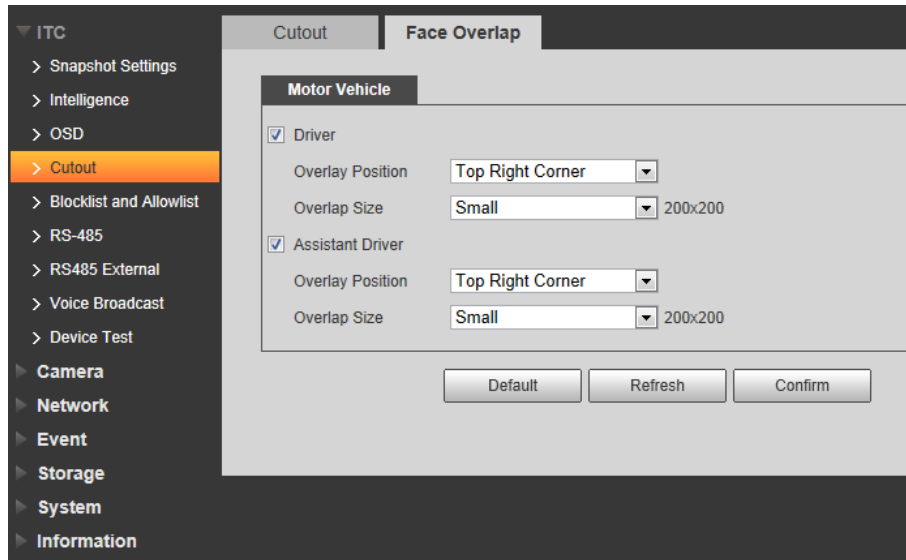

Step 3 Click **Confirm**.

4.5.1.5 Blocklist and Allowlist

4.5.1.5.1 Fuzzy Matching

Enable fuzzy match, and set the fuzzy match conditions. The vehicle with plate meeting the matching conditions will be considered as allowlist vehicle, and the Camera will automatically open the barrier.

Step 1 Select **Setting > ITC > Blocklist and Allowlist > Fuzzy Matching**.

Figure 4-42 Fuzzy matching

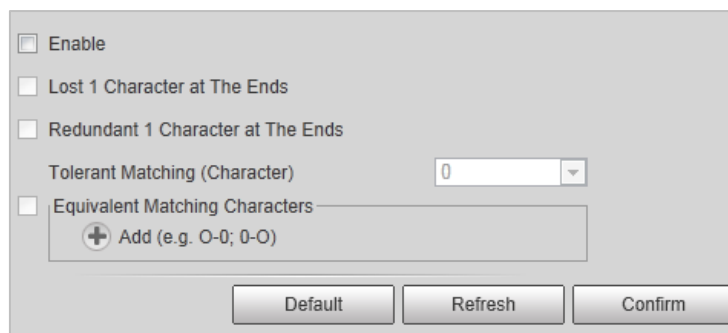

Step 2 Select the **Enable** check box to enable fuzzy match, and then configure the parameters as needed.

Table 4-17 Allowlist parameters description

Parameter	Description
Lost 1 Character at The Ends	Plate number will be matched when the first or last character of the detected plate is missing.
Redundant 1 Character at the Ends	Plate number will be matched when one more character is detected before the first character or after the last character of the plate.
Tolerant Matching (Character)	Set the tolerant matching value (0 , 1 , or 2), and plate number will be matched successfully when 0, 1, or 2 characters different from the recorded plate number are detected.
Equivalent matching Characters	Click  to add the fuzzy match condition. For example, if o is detected by the Camera, the character will be automatically recognized as 0, as shown in the figure above.

Step 3 Click **Confirm**.

4.5.1.5.2 Allowlist

You can search, and check whether a plate number is included in the allowlist, or you can import or export plate number in the allowlist.

Step 1 Select **Setting > ITC > Blocklist and Allowlist > Allowlist**.

Figure 4-43 Allowlist

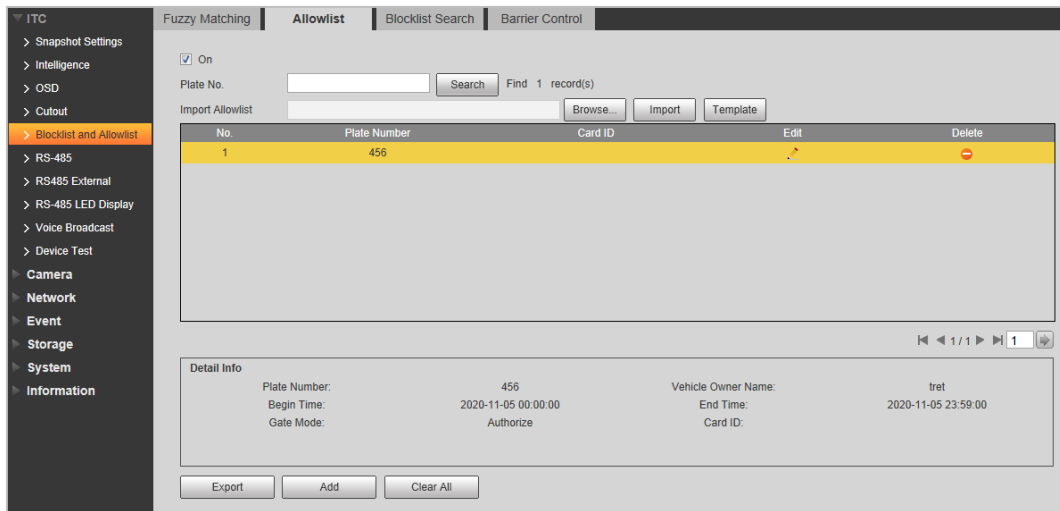

Step 2 Configure parameters.



- Plate No.: Enter the plate number (enter some characters). Click **Search**, and check whether the plate number exists in the allowlist.
- Edit plate information: Click  of the corresponding plate number searched, and edit the plate number.
- Delete single plate number: Click  of the corresponding plate number searched, and delete it from the allowlist.
- Delete plate number in batches: click **Clear All**, and then click **Confirm** in the dialog box to delete all the allowlist information.
- Adding vehicles to allowlist one by one:
 - 1) Click **Add**.

Figure 4-44 Add



- 2) Enter complete plate number, and card ID.
- 3) Set the **Begin Time**, and **End Time** of the plate number which exists in allowlist. The vehicle will be no longer considered as allowlist vehicle beyond the defined time range.
- 4) Enter **Vehicle Owner Name**, and select **Gate Mode** (barrier gate) from **No Authorize** (no permission of auto opening barrier), and **Authorize** (auto opening barrier) as needed.

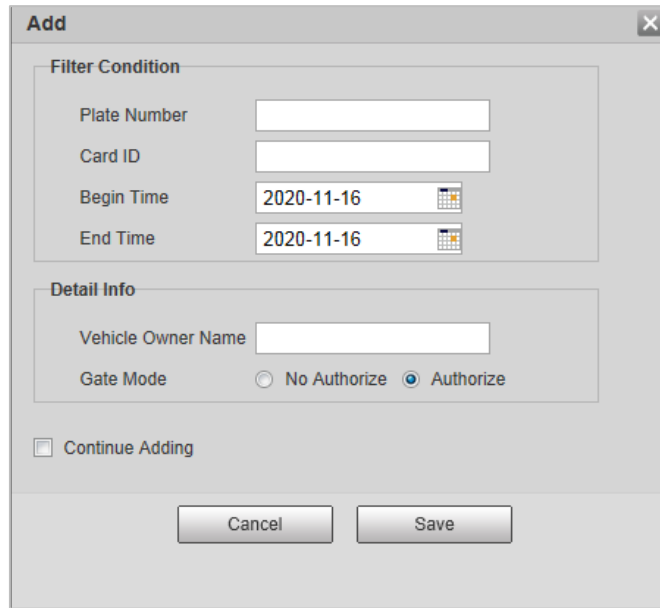

You need to enable barrier control from **Setting > ITC > Blocklist and Allowlist > Barrier Control**.

- 5) Select **Continue Adding**, click **Save**, and the system will save allowlist plate number information, and directly enter the adding page of next allowlist plate.



You can also cancel selecting **Continue Adding**, and then click **Save** to stop adding further vehicles.

- Exporting vehicles to allowlist in batches:
 - 1) Click **Export**, and it pops up the **Encrypt Config** dialog box.
 - 2) Check **Open** (encrypt) or **Off** (do not encrypt) as needed, and then click **Confirm**.

Figure 4-45 Encrypt config

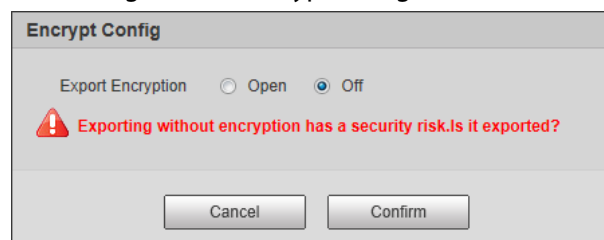

- 3) Select the path of storing files. Click **Save**, and export allowlist to local in .csv format, which can be opened in Excel.
- Importing vehicles to allowlist in batches:
 - 1) Click **Template** to download the template, or open the .csv file you exported, fill in the

allowlist data which needs to be imported according to template format, and then save the file.

- 2) Click **Browse...**, and select the path where template file exists.
- 3) Click **Import**, and you can import the allowlist data into the system in batches.



Make sure that the time format in list is in accordance with that of the Camera when importing allowlist.

4.5.1.5.3 Blocklist Search

You can search, and check whether some plate exist in the blocklist, import, and export Blocklist plate number, and vehicle information.

Step 1 Select **Setting > ITC > Blocklist and Allowlist > Blocklist Search**.

Figure 4-46 Blocklist search

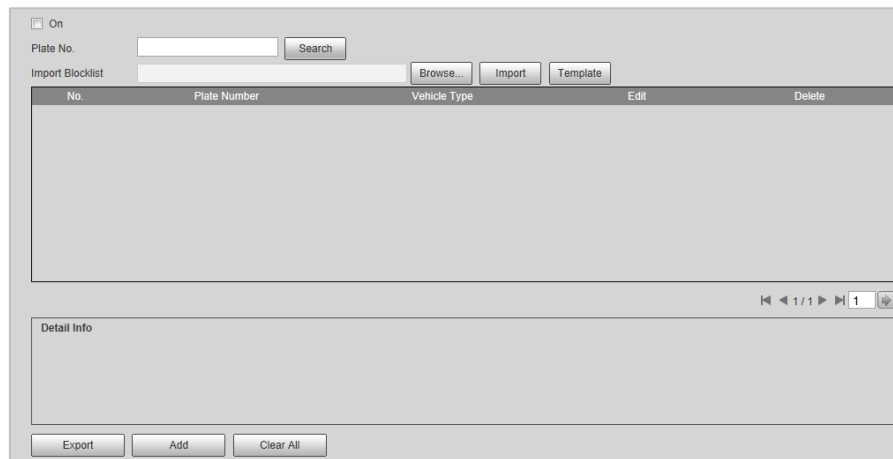

Step 2 The query, import, and export of blocklist is similar to those of allowlist. For details, see "4.5.1.5.2 Allowlist".

4.5.1.5.4 Barrier Control

You can set the barrier control mode, and configure information of opening, and closing barrier.

Step 1 Select **Setting > ITC > Blocklist and Allowlist > Barrier Control**.

Figure 4-47 Barrier control

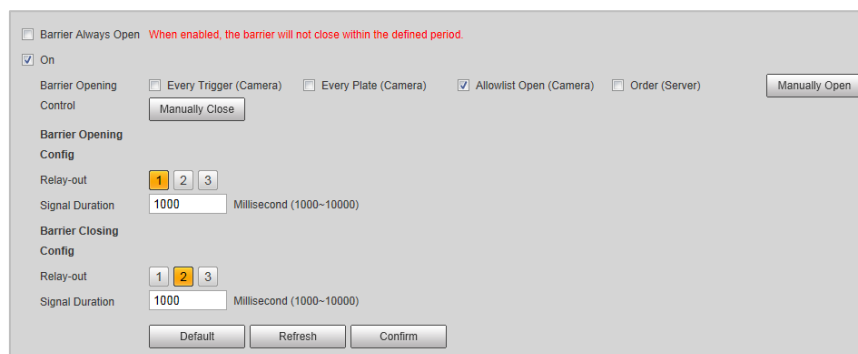

Step 2 Configure parameters.

Table 4-18 Barrier control parameter description

Parameter	Description
Barrier Always Open	Select it, and enable the function of barrier always open. Configure the period of barrier always open. The barrier will not close during the defined period.
On	Select it to enable barrier control, and configuration.
Barrier Opening Control	<p>Triggers alarm through different modes, and remotely controls the barrier opening and close.</p> <ul style="list-style-type: none"> • Every Trigger (Camera): Capture any vehicle, and output open barrier signal. • Every Plate (Camera): Capture any plated vehicle, and output open barrier signal. • Allowlist Open (Camera): Capture the vehicle which conforms to allowlist or fuzzy matching, and then output open barrier signal. • Order (Server): Platform sends command, and output open barrier signal. <p> You can configure barrier opening control as Allowlist Open (Camera), and Order (Server) at the same time. Allowlist Open (Camera) takes priority.</p>
Barrier Opening Config	<ul style="list-style-type: none"> • Relay-out: Alarm linkage output port. You can select anyone one of the 3 ports.
Barrier Closing Config	<ul style="list-style-type: none"> • Signal Duration: The duration that the barrier opening or closing signal lasts.

Step 3 Click **Confirm**.

4.5.1.6 RS-485

You can configure the RS-485 serial protocol of the external device. After configuration, you can set related parameters of the device on Web.

Step 1 Select **Setting > ITC > RS-485 > Trigger Mode**.

Step 2 Configure parameters.

1) DHRS.

Figure 4-48 DHRS parameters

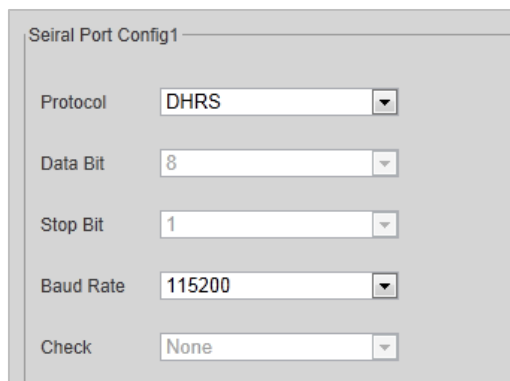

The screenshot shows a web interface titled "Serial Port Config1" with the following configuration options:

- Protocol: DHRS
- Data Bit: 8
- Stop Bit: 1
- Baud Rate: 115200
- Check: None

Table 4-19 DHRS parameters description

Parameter	Description
Data Bit	8 by default, and cannot change.
Stop Bit	1 by default, and cannot change.
Baud Rate	The transmission speed of the code element. Options are 4800, 9600, 19200, 38400, 115200.
Check	None by default, and cannot change.

2) RS-485 transparent transmission.

The third party platform can control the RS-485 output of the Camera through RS-485 transparent transmission, and then you can connect external devices.

Trigger capture through transmitting capture command. To test the RS-485 transparent transmission sending, and receiving conditions, select **Hexadecimal Sending**, and then click **Open** on the right side of **Receiving Area**.

Figure 4-49 RS-485 transparent transmission

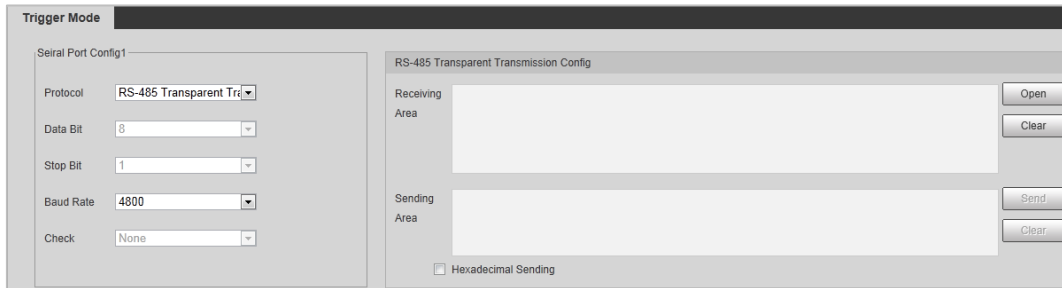

3) Serial port push.

You can configure the serial port push information. The camera pushes the snapshots to the third serial collection device through RS-485.

Figure 4-50 Serial port push

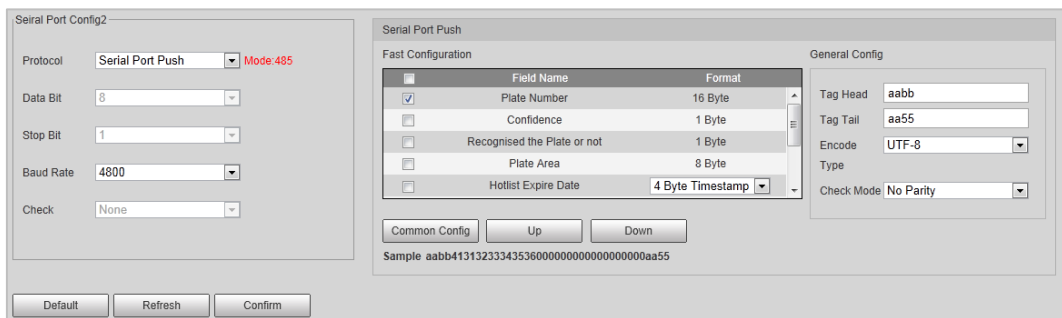



Table 4-20 Serial port push parameter description

Parameter	Description	
Quick configuration	Field Name  Hover over the fields, you can see the explanations. Select the check box next to Field Name to select all the fields.	
	Format	Format of the fields.
	Common Config	Click to restore to commonly selected fields (default).

Parameter		Description
	Up/Down	Click to move the field position up or down.
General config	Tag Head	The tag head of data package. It is aabb by default.
	Tag Tail	The tag tail of data package. It is aa55 by default.
	Encode Type	Select encode type from UTF-8 (default) and GB2312 .
	Check Mode	Select check mode from No Parity , Checksum and XOR Check .

Step 3 Click **Confirm**.

4.5.1.7 RS-485 LED Display

Connect the LED display with the Camera through RS-485, and then you can configure the status, display type, display color, action, speed, and more parameters of the LED.

Step 1 Select **Setting > ITC > RS-485 LED Display**.

Figure 4-51 RS-485 LED display

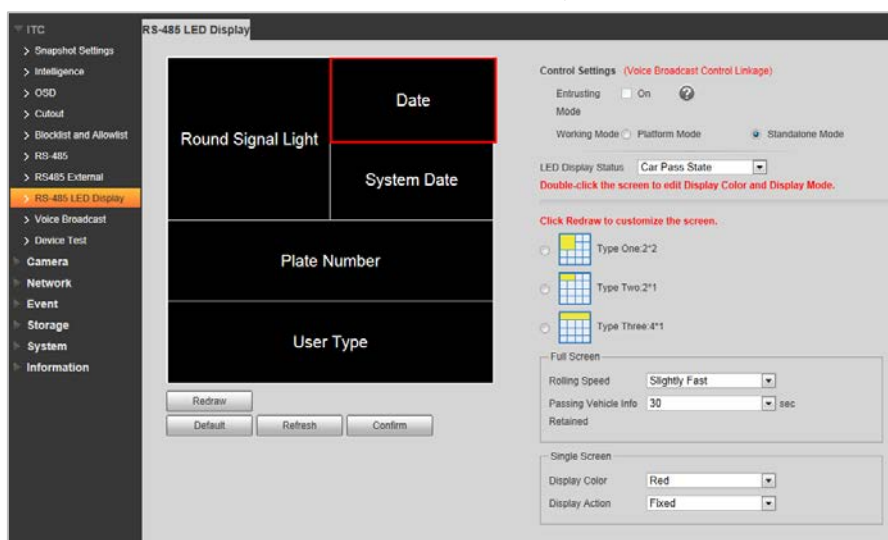

Step 2 Configure LED parameters.

Table 4-21 LED parameters description

Parameter	Description
Entrusting Mode	Select On , and then the LED will be totally controlled by superior platform. The protocol must be supported by the platform.
Working Mode	<ul style="list-style-type: none"> • Platform Mode: Select this to allow platform to control LED display information. • Stand-alone Mode: Display as configured, and not controlled by any platforms.
LED Display Status	Select from Car Pass State , and Normal Status . The LED screen will display as configured during the time period of either status.
Drawing Type	Select display type from 2 × 2, 2 × 1, and 4 × 1.

Parameter	Description
Full Screen	<ul style="list-style-type: none"> Rolling Speed: The rolling speed of the information on LED, including Slow, Slightly Slow, Medium, Slightly Fast (default), and Fast. Passing Vehicle Info Retained: The display duration of the passing vehicle information on LED, including 10 s, 20 s, 30 s (default), 40 s, 50 s, and 60 s.
Single Screen	<ul style="list-style-type: none"> Display Color: Select information display color on LED. Display Action: Select information display action on LED from Fixed, and Roll. Display Field: Right-click on a screen to select display field.

Step 3 (Optional) Click **Redraw** to change the LED display. You can select the drawing type, display field, and other parameters referring to above parameter description.

Step 4 Click **Confirm**.

4.5.1.8 Voice Broadcast

You can configure the voice broadcast content, volume, and encoding of the ANPR camera.

4.5.1.8.1 Broadcast Content

Configure the broadcast content, and the Camera will broadcast the content when vehicles passing.



Some devices do not support voice.

Step 1 Select **Setting > ITC > Voice Broadcast > Broadcast Content**.

Step 2 Select broadcast options as needed.





If the **Barrier Control** is selected as **Order (Server), Parking Fee, Parking Duration, Expire At**, and **Entry/Exit Time** will be available after the voice broadcast is controlled by the platform.

Figure 4-52 Broadcast content

Step 3 Configure parameters.

Table 4-22 Broadcast content parameters description

Parameter	Description
Insert Before	Insert an option before the selected one on the display area.
Insert After	Insert an option after the selected one on the display area.
Edit	Click  next to the broadcast option to edit the prefix, and suffix of the option.
Delete	Click  next to the broadcast option to delete the option.
Clear	Delete all broadcast options.

Step 4 Click **Confirm**.

4.5.1.8.2 Volume/Encoding

Configure the volume of voice broadcast.

Step 1 Select **Setting > ITC > Voice Broadcast > Volume/Encoding**.

Step 2 Configure the input volume, output volume, and speaking speed as needed.

Figure 4-53 Volume/Encoding

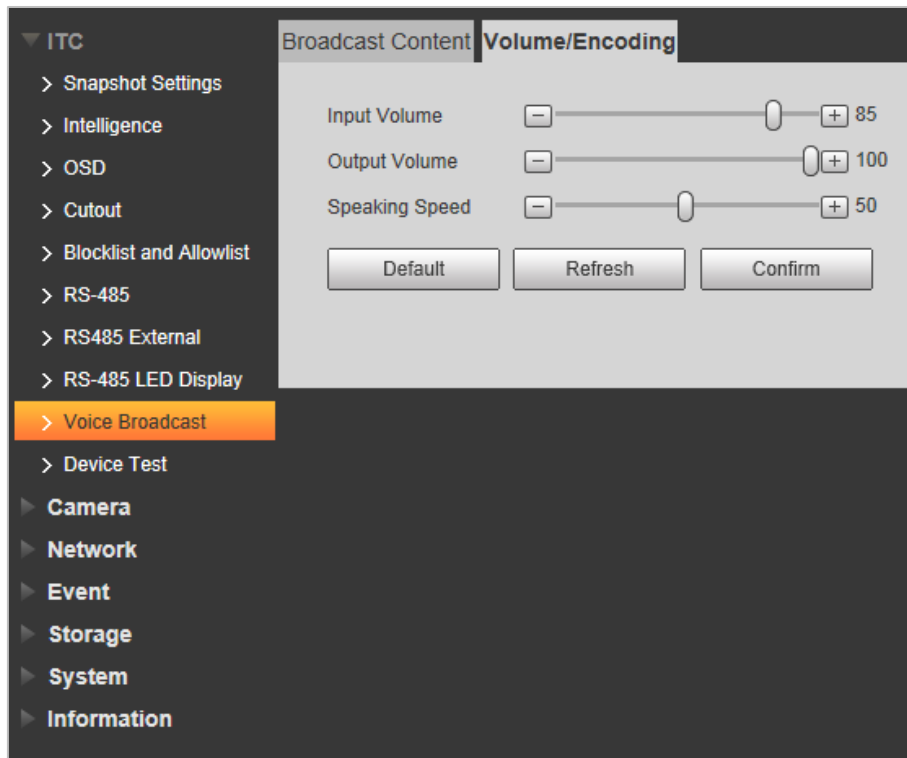

Step 3 Click **Confirm**.

4.5.1.9 Device Test

4.5.1.9.1 Device Test

You can test the barrier opening, and closing, capture, display content, voice broadcast, and abnormal configuration modules to see if they work as configured. You can also export related device information.

Step 1 Select **Setting > ITC > Device Test > Device Test.**

Figure 4-54 Device test

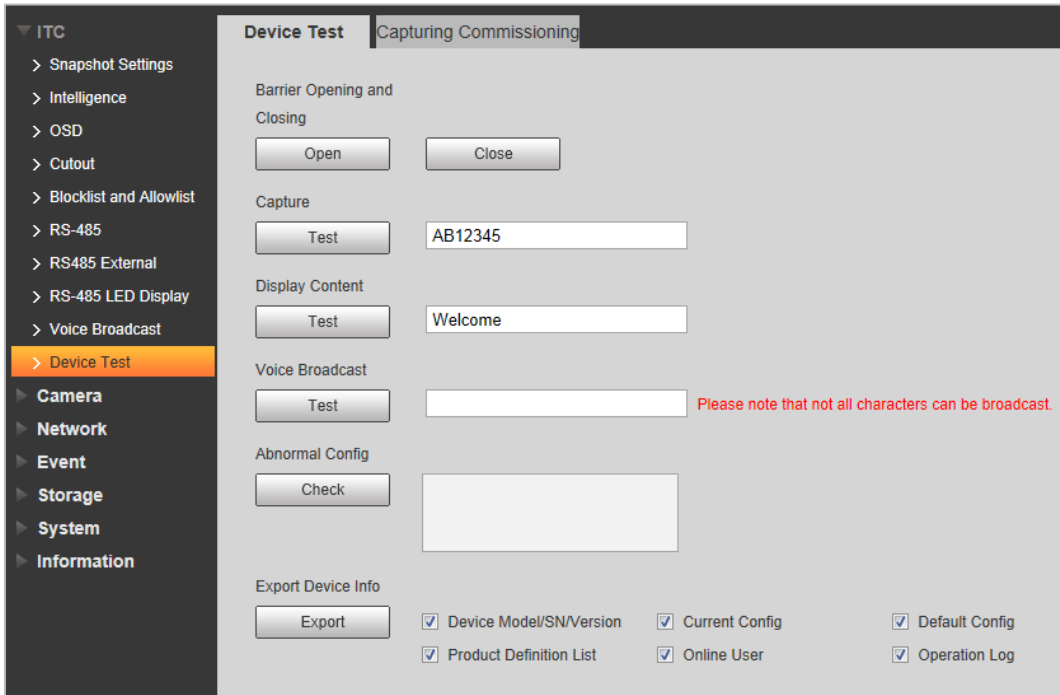

Step 2 Configure parameters.

Table 4-23 Device test parameter description

Parameter	Description
Barrier Opening, and Closing	Click Open or Close to test the barrier.
Capture	Click Test to stimulate capture, and view the snapshot in Live page.
Display Content	Click Test , and view whether the LED screen displays as configured.
Voice Broadcast	Click Test to check whether the device plays sound normally.  Voice broadcast is available on select models.
Abnormal Config	Click Check , and system checks abnormality automatically.
Export Device Info	Select device information as needed, and export in batches.

4.5.1.9.2 Capturing Commissioning

You can overlay recognition area box, snap line, filtering area box, vehicle box, and license plate box on the snapshots to help check the effect of the capturing commissioning.

Step 1 Select **Setting > ITC > Device Test > Capturing Commissioning.**

Step 2 Select **Overlay lines**, and **tracking info** check box, and then select types as needed.

Figure 4-55 Capturing commissioning

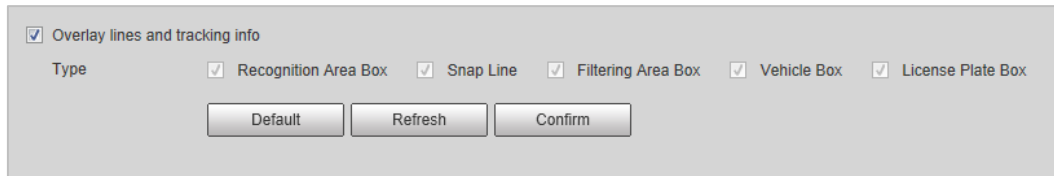

Step 3 Click **Confirm**.

Step 4 Go to **Live** page, and then click  to manually capture plate. On the snapshot, you can see the selected line information, and you can adjust the capture line, and others as needed.

4.5.2 Camera

You can configure image, video, and stream parameters.

4.5.2.1 Attribute

You can adjust the brightness, contrast, saturation of the video image, and set shutter parameters to get clear videos, and recordings that you want.

4.5.2.1.1 General

This section provides guidance on configuring parameters such as image brightness, contrast, saturation, and hue.

Step 1 Select **Setting > Camera > Attribute > General**.

Figure 4-56 General settings

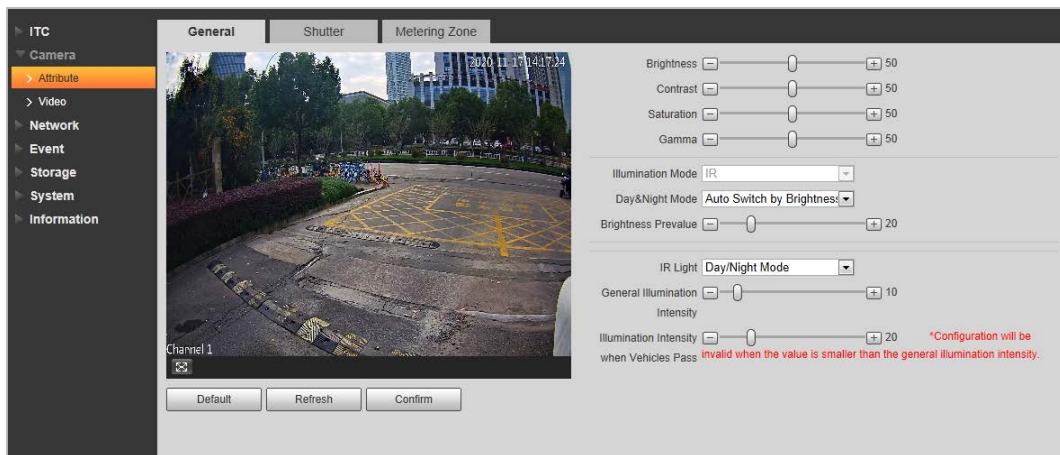

Step 2 Configure parameters.

Table 4-24 General parameters description

Parameter	Description
Brightness	<p>Adjust the overall image brightness. Change the value when the image is too bright or too dark.</p> <p>The bright, and dark areas will have equal changes. The image becomes blurry when the value is too big. The recommended value is from 40 to 60. The range is from 0 to 100.</p> <p>It is 50 by default. The bigger the value is, the brighter the image becomes.</p>

Parameter	Description
Contrast	<p>Change the value when the image brightness is proper but contrast is not enough.</p> <ul style="list-style-type: none"> • If the value is too big, the dark area is likely to become darker, and the bright area is likely to be overexposed. • The picture might be blurry if the value is set too small. The recommended value is from 40 to 60, and the range is from 0 to 100. <p>It is 50 by default. The bigger the value is, the more obvious the contrast between the bright area, and dark area will become.</p>
Saturation	<p>Adjust the color vividness, and will not influence the image overall brightness.</p> <ul style="list-style-type: none"> • The image becomes too flamboyant if the value is too big. • The image is not flamboyant enough if the value is too small. The recommended value is from 40 to 60, and the range is from 0 to 100. <p>It is 50 by default. The bigger the value is, the more flamboyant the image becomes.</p>
Gamma	Adjust the image brightness level. The higher the value, the brighter, and blurry the image.
Illumination Mode	Only supports IR illumination.
Day&Night Mode	<ul style="list-style-type: none"> • Color: Applicable in the day, image shows in colors. • B/W: Applicable at night, the image is black, and white. • Auto Switch by Brightness: Set the brightness prevalue. When the brightness is higher or lower than the prevalue, the image shows in colors or black, and white respectively.
Brightness Prevalue	Prevalue of brightness. You can drag the slider to adjust the value. The higher the value, the brighter the video image.
IR Light	<ul style="list-style-type: none"> • Always Off: Set the IR light to always on. • Always On: Set the IR light to always off. • Day/Night Mode: Automatically turn on or off the IR light according to the configured Day/Night mode. <p> Available on some devices.</p>
General Illumination Intensity	Set the illumination intensity when there are no vehicles passing.
Illumination Intensity when Vehicles Pass	Set the illumination intensity when there are vehicles passing.

Step 3 Click **Confirm**.

4.5.2.1.2 Shutter

This section provides guidance on configuring camera shutter, including shutter mode, exposure mode, gain mode, and scene mode.

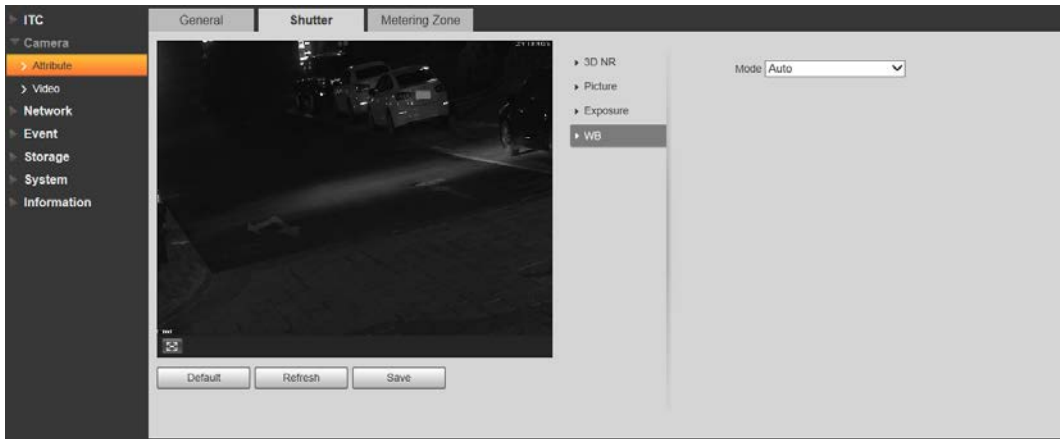

Step 1 Select **Setting > Camera > Attribute > Shutter**.

Figure 4-57 Shutter



Step 2 Configure parameters.

Table 4-25 Shutter parameters description

Parameter	Description
3D NR	
Video Tridim Denoise	When it is On , 3D NR is enabled to reduce noise of video.
Video Spatial	Spatial video denoising. The higher the value, the fewer the noise.
Video Temporal	Temporal video denoising. The higher the value, the fewer the flicker noise.
Picture	
Scene	You can change the scene, and adjust the sharpness of corresponding scene. Scenes available: Dawn/Dusk , Daytime , and Night .
Sharpness	You can set the sharpness of corresponding scene. The higher the value, the clearer the image. But there will be noise if sharpness is too high.
WDR	Select On to enable WDR (wide dynamic range), which helps provide clear video images in bright, and dark light.
Exposure	
Iris Adjust Mode	Select the iris adjust mode from Off , and Auto .
Mode	Select the way of adjusting exposure mode. You can select from Manual , and Auto .
Shutter	 You need to set shutter when set Mode to Manual .
Shutter Scope	Set the time range of shutter.  You need to set shutter when Customized Range is set as Shutter .
Gain Scope	Set the value range of gain.  You need to set gain scope when set Mode to Manual .
WB	
Mode	Set scene mode to adjust the image to its best status.

Step 3 Click **Save**.

4.5.2.1.3 Metering Zone

This section provides guidance on setting the measure mode of metering zone.

Step 1 Select **Setting > Camera > Attribute > Metering Zone**.

Figure 4-58 Metering Zone

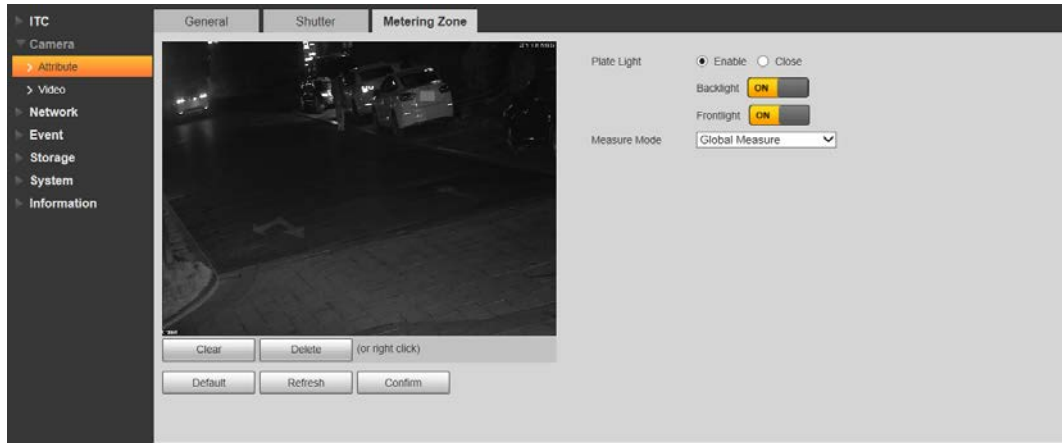

Step 2 Configure parameters.

Table 4-26 Metering zone parameter description

Parameter	Description
Plate Light	When selecting Enable , you can turn ON or OFF backlight, and frontlight according to scene requirement, and then improve the backlight image brightness.
Backlight	
Frontlight	
Measure Mode	<ul style="list-style-type: none">● Global Measure: Measure the brightness of the whole image area, and intelligently adjust the overall image brightness.● Partial Measure: Measure the brightness of sensitive area, and intelligently adjust the overall image brightness. If the measured area becomes bright, then the whole area becomes dark, and vice versa. Drag to select the measured area, and the system displays yellow box. Drag the box to proper location, and then click Confirm to complete configuration.

Step 3 Click **Confirm**.

4.5.2.2 Video

4.5.2.2.1 Video

You can set the camera stream information.

Step 1 Select **Setting > Camera > Video > Video**.

Figure 4-59 Video

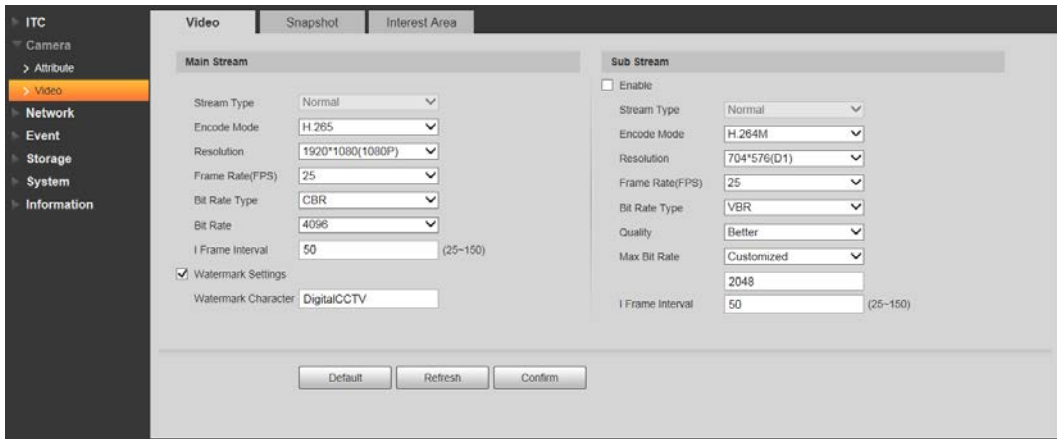

Step 2 Configure parameters.

Table 4-27 Video parameters description

Parameter		Description
Main Stream	Stream Type	Currently it supports normal stream.
	Encode Mode	Currently it only supports H.264B, H.264M, H.264H, H.265, and MJPEG.
	Resolution	Select the resolution of the video.  The resolution of sub stream cannot be greater than main stream.
	Frame Rate(FPS)	Select frame rate as needed.
	Bit Rate Type	Include VBR, and CBR. Image quality can only be set in VBR mode.
	Bit Rate	The value is the upper limit of the stream in VBR mode while it is fixed in CBR mode.
	I Frame Interval	Frame or time interval between two I frames. The bigger the interval, the smaller space taken by the decompressed video. The system default is set twice as big as frame rate.
Sub Stream	Watermark Settings	You can view if the video is tampered through verifying watermark character. <ul style="list-style-type: none"> • Select Watermark Settings, and enable the function. • Watermark Character is DigitalCCTV by default. • The watermark character can only consist of number, letter, underline, and maximum length contains 85 characters.
	Enable	Select it, and enable sub stream.
	Quality	Image quality can be set in VBR mode. There are 6 levels optional.
	Max Bit Rate	The value is the upper limit of the stream in VBR mode while it is fixed in CBR mode.

Step 3 Click **Confirm**.

4.5.2.2.2 Snapshot

You can set the picture stream, including resolution, quality or picture size.

Step 1 Select **Setting > Camera > Video > Snapshot**.

Figure 4-60 Snapshot

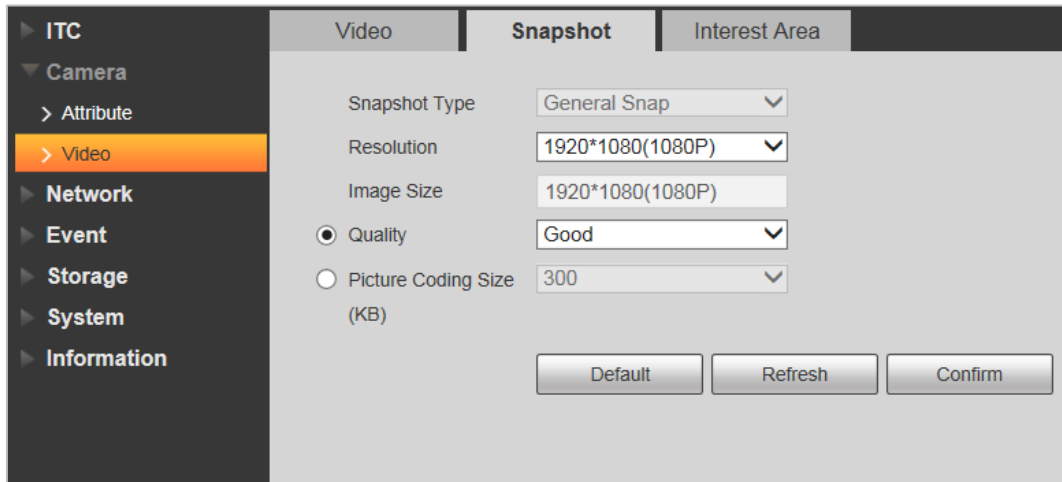

Step 2 Configure parameters.

Table 4-28 Snapshot parameters description

Parameter	Description
Snapshot Type	Currently it only supports general snapshot.
Resolution	The snapshot resolution.
Image Size	It is in accordance with resolution value.
Quality	Set the snapshot quality which includes 6 levels optional.
Picture Coding Size (KB)	Select picture coding size from 8 options, or select Custom to define the size (50–1024).  You can only select one between picture quality and picture coding size to set the configuration.

Step 3 Click **Confirm**.

4.5.2.2.3 Interest Area

Set interest area in the image, and then the selected image will display with configured quality.



- It supports max 3 regions at the same time.
- The image quality is displayed by level: **Worst, Worse, Bad, Good Better, or Best**.
- Click **Clear**, and delete all the area boxes; Select one box, and then click **Delete** or right-click to delete it.

Step 1 Select **Setting > Camera > Video > Interest Area**.

Figure 4-61 Interest area

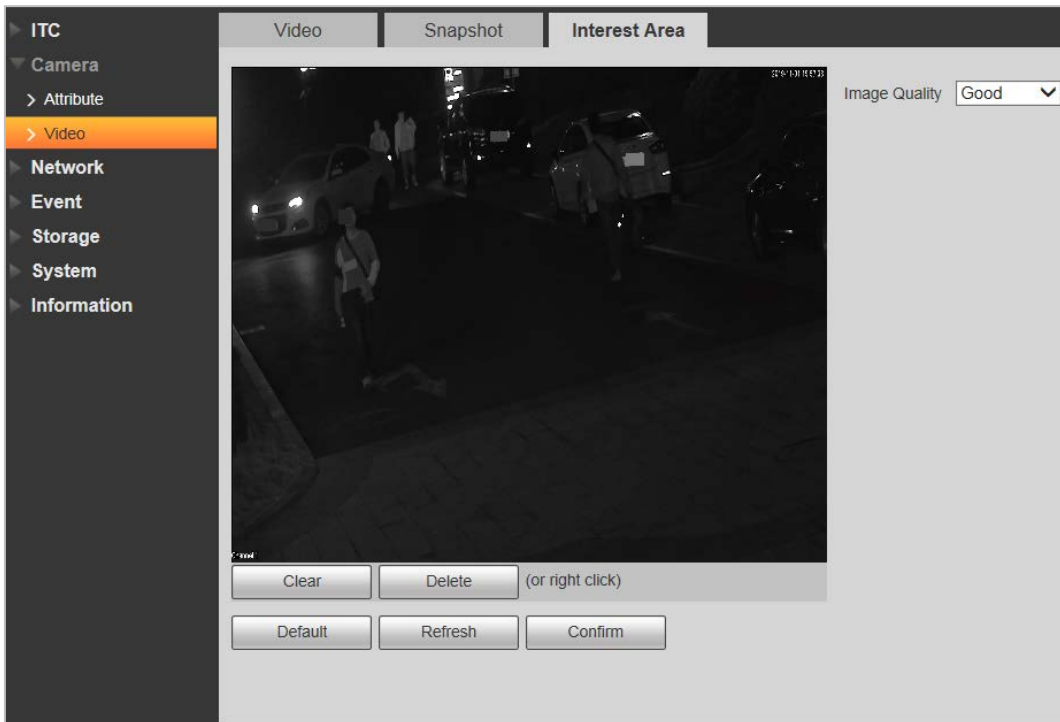

Step 2 Configure parameters.

Table 4-29 Interest area parameter description

Parameter	Description
Image Quality	Set snapshot quality, which includes 6 levels optional.
Clear	Delete all the configured regions.
Delete	Delete the latest ROI. You can click it for several times. Right-click any position in the image to realize the same effect.

Step 3 Click **Confirm**.

4.5.3 Network

You can set IP address, port, and other parameters.

4.5.3.1 TCP/IP

Configure the IP address of the Camera, and DNS server so that the Camera can connect with other devices in the network.



Some models support dual network port. Do not set them in the same network segment; otherwise it might cause network error.

Step 1 Select **Setting > Network > TCP/IP**.

Figure 4-62 TCP/IP

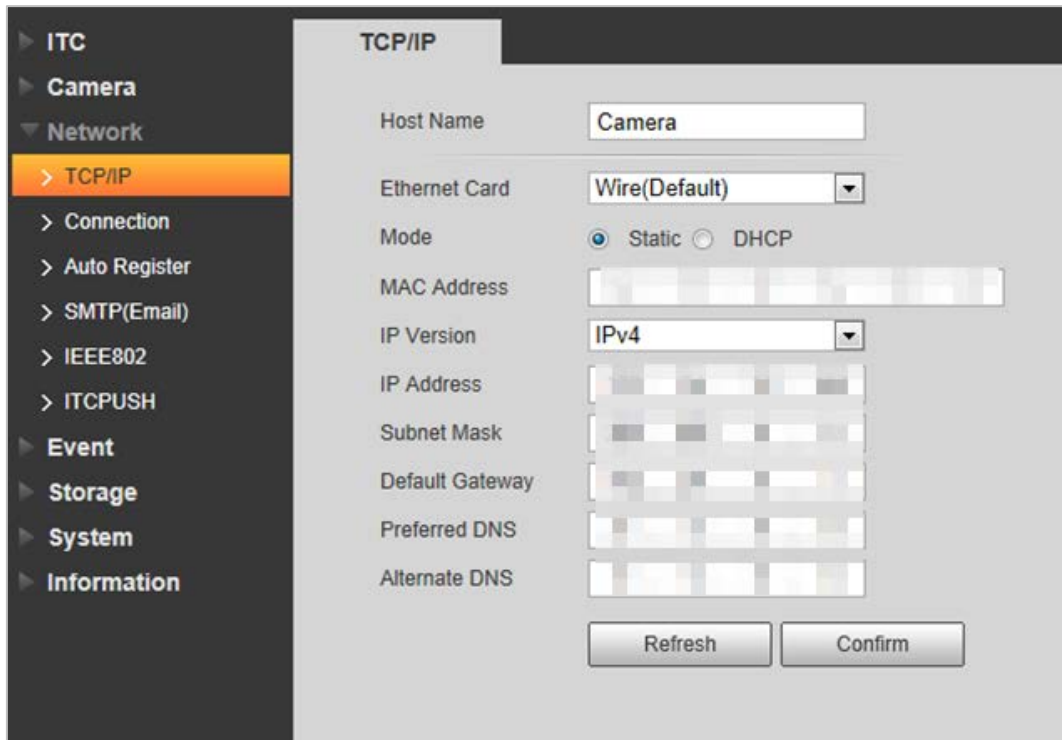

Step 2 Configure parameters.

Table 4-30 TCP/IP parameter description

Parameter	Description
Host Name	Enter a name (Maximum 15 characters) for the host device.
Ethernet Card	Select the Ethernet card. The default setting is Wire .
Mode	Network mode, including static, and DHCP. <ul style="list-style-type: none"> • Static: Manually set IP, subnet mask, and gateway. • DHCP: Automatically acquire IP. At this moment, IP, subnet mask, and gateway cannot be set.
MAC Address	MAC address of the host.
IP Version	Includes IPv4 , and IPv6 . The IP address of both versions can be accessed.
IP Address	Device IP Address.
Subnet Mask	The corresponding subnet mask of device IP address.
Default Gateway	Corresponding gateway of device IP address.
Preferred DNS	IP address of DNS server.
Alternate DNS	Alternative IP address of DNS server.

Step 3 Click **Confirm**.

4.5.3.2 Connection

4.5.3.2.1 Port

You can set the maximum number, and value of the ports.

Step 1 Select **Setting > Network > Connection > Port**.

Figure 4-63 Port

The screenshot shows the 'Port' configuration page in a camera's web interface. The left sidebar contains a navigation menu with the following items: ITC, Camera, Network (expanded), TCP/IP, Connection (highlighted), Auto Register, SMTP(Email), IEEE802, ITCPUSH, Event, Storage, System, and Information. The main content area is titled 'Port' and contains the following configuration fields:

- Max Connection: 10 (range 1~20)
- TCP Port: 37777 (range 1025~65535)
- UDP Port: 37778 (range 1025~65534)
- HTTP Port: 80
- RTSP Port: 554
- HTTPS Port: 443

At the bottom of the configuration area, there are three buttons: 'Default', 'Refresh', and 'Confirm'.

Step 2 Configure each port value of the Camera.

Table 4-31 Connection parameters description

Parameter	Description
Max Connection	The maximum number of clients (such as web client, and platform client) that are allowed to access the Camera simultaneously. It is 10 by default.
TCP Port	Protocol communication port. It is 37777 by default.
UDP Port	User data packet protocol port. It is 37778 by default.
HTTP Port	HTTP communication port. It is 80 by default.
RTSP Port	Media streaming control port. It is 554 by default.
HTTPS Port	HTTPS communication port. It is 443 by default.

Step 3 Click **Confirm**.

4.5.3.2.2 ONVIF

You can enable the Open Network Video page Forum (ONVIF) function to make network video products of different manufacturers interworking.



ONVIF login authentication is enabled by default.

Step 1 Select **Setting > Network > Connection > ONVIF**.

Figure 4-64 ONVIF

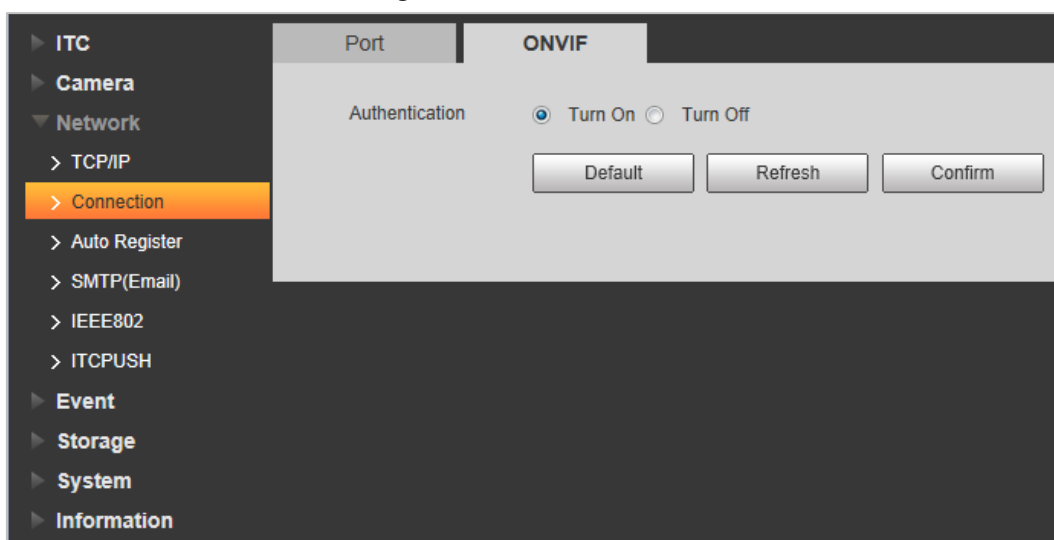

Step 2 Select the **Turn on** check box.

Step 3 Click **Confirm**.

4.5.3.3 Auto Register

Through auto register function, when the device is connected with external network, system will report its current location to the server so that client platform can access device through server.

Step 1 Select **Setting > Network > Auto Register > Auto Register**.

Step 2 Check **On** to enable the function.

Figure 4-65 Auto register

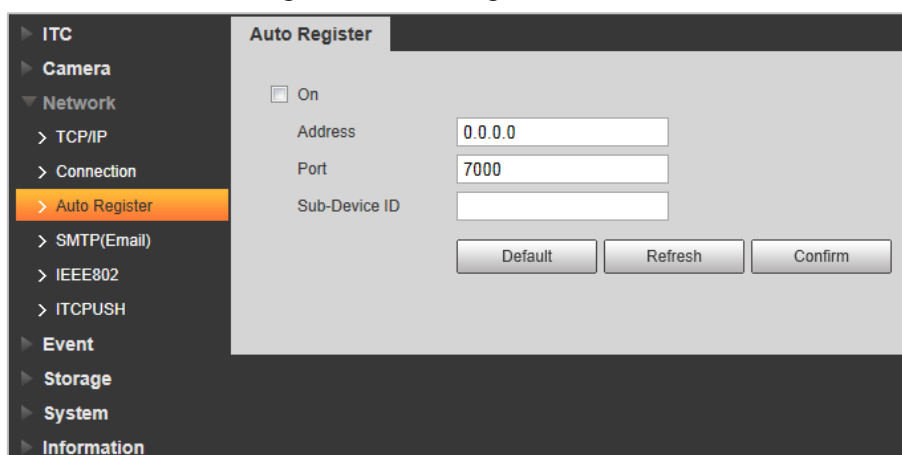

Step 3 Configure parameters.

Table 4-32 Auto register parameter description

Parameter	Description
Address	The IP address of the server on which the device register.
Port	The port of the server for auto registration.
Sub-Device ID	The device ID distributed by the server for auto registration. Make sure that the ID is unique during auto registration.

4.5.3.4 SMTP (Email)

Configure the email, and when alarms or abnormal events are triggered, an email will be sent to the recipient server through SMTP server. The recipient can log in to the incoming mail server to receive emails.



After enabling this function, system will send the device data to the given server. There is data leakage risk.

Step 1 Select **Setting > Network > SMTP (Email)**.

Figure 4-66 SMTP (email)

Step 2 Configure parameters.

Table 4-33 SMTP (Email) parameter description

Parameter	Description
SMTP Server	IP address of the outgoing mail server that complies with SMTP protocol.
Port	Port number of the outgoing mail server complying with SMTP protocol. It is 25 by default.
Username	Username of sender mailbox.
Password	Password of sender mailbox.
Anonymity	For servers supporting anonymous email, you can log in anonymously without entering username, password, and sender information.
Sender	Email address of the sender.

Parameter	Description
Encryption Type	Select encryption type from None , SSL , and TLS .
Title	You can enter no more than 63 characters in English letters, and numbers.
Mail Receiver	Email address of the receiver. Supports 3 addresses at most.
Attachment	Select the check box to support attachment in the email.
Interval	The interval of sending emails.
Health Mail	The system sends test mail to check whether the connection succeeds. Select the Health Mail check box, and configure the Update Period , and then the system sends test mails according to the defined period.
Test	Test whether the email function is normal. If the configuration is correct, the email address of the receiver will receive the test email. Save the email configuration before running rest.

Step 3 Click **Save**.

4.5.3.5 IEEE802

Step 1 Select **Setting > Network > IEEE802**.

Figure 4-67 IEEE802

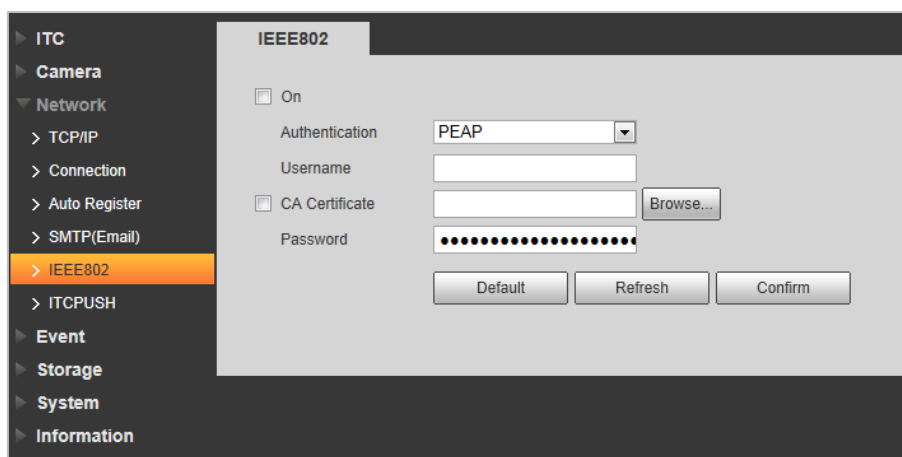

Step 2 Select **On** check box to enable IEEE802, and then configure parameters.

Table 4-34 IEEE802 parameters description

Parameter	Description
Authentication	<ul style="list-style-type: none"> • PEAP: Ordinarily uses TLS only to authenticate the server to the client, and only the sever is required to have a public key certificate. • EAP-TLS: Provides mutual authentication of client to server, and server to client. Both the client, and the server must be assigned a digital certificate signed by a CA (Certificate Authority) that they both trust.
CA Certificate	Select CA Certificate check box, and then click Browse to import the CA certificate to verify whether the switch is valid.
PEAP	
Username	For PEAP method, user authentication is performed by using

Parameter	Description
Password	password-based credentials (username, and password).
EAP-TLS	
Client Certificate	Click Browse to import the client certificate, and private key files for authentication.
Private Key	

Step 3 Click **Confirm**.

4.5.3.6 ITC Push

You can configure this parameter to push the captured vehicle violations information to the server.

Step 1 Select **Setting > Network > ITC PUSH**.

Figure 4-68 ITC push configuration

Step 2 Configure parameters.

Table 4-35 ITC push parameter description

Parameter	Description
On	Select On check box to push passing vehicles information.
No Plate Upload	Select No Plate Upload check box to push the unlicensed vehicle information.
Username	Username, and password for logging in to server.
Password	
Web URL	Http URL prefix information of uploaded picture data.
Device ID	Displays the device ID information.
Http Time Out(s)	Time limit (0–65535) of the device requesting access to cloud sites. Uploading data will fail if the limit is exceeded.
Keep Alive Time(s)	Time period (0–65535) of keeping the device connected with cloud sites after uploading data. It is 30 s by default.
Character Encoding	Encoding mode of the pushed content. <ul style="list-style-type: none"> • UTF8: Applicable for all languages • GB2312: Only applicable for Chinese Simplified.

Parameter	Description
Upload List Type	Select the type of list that you want to upload.
Push Picture Config	Select the pushed picture type, including Original Image , Plate Picture , and Vehicle Body Picture .
Upload Info Config	Select the information that you want to upload.

Step 3 Click **Save**.

4.5.4 Event

This section provides guidance on configuring alarm, and abnormality.

4.5.4.1 Alarm

4.5.4.1.1 Relay Activation

You can set several parameters of relay activation such as relay-in, period, anti-dither, and sensor type. When triggering alarm, the system sends the alarm signal to external devices to trigger, for example, buzz.

Step 1 Select **Setting > Event > Alarm > Relay Activation**.

Figure 4-69 Relay activation

Step 2 Select **On** checkbox to enable alarm input for the current channel.

Step 3 Select alarm input channel.

Step 4 Set the period of alarm input.

1) Click **Setting**.

Figure 4-70 Period

The screenshot shows a window titled "Period" with a close button in the top right corner. The main area contains a 24-hour grid for each day of the week (Sun, Mon, Tue, Wed, Thu, Fri, Sat). The x-axis is labeled with even numbers from 0 to 24. Each day's row has a solid green bar from 00:00 to 23:59. To the right of the grid are seven "Setup" buttons, one for each day.

Below the grid is a list of days with checkboxes: All, Sun, Mon, Tue, Wed, Thu, Fri, Sat.

Below the days are six "Period" settings, each with a checkbox and a time range:

<input checked="" type="checkbox"/> Period1	00 : 00 : 00	-	23 : 59 : 59
<input type="checkbox"/> Period2	00 : 00 : 00	-	23 : 59 : 59
<input type="checkbox"/> Period3	00 : 00 : 00	-	23 : 59 : 59
<input type="checkbox"/> Period4	00 : 00 : 00	-	23 : 59 : 59
<input type="checkbox"/> Period5	00 : 00 : 00	-	23 : 59 : 59
<input type="checkbox"/> Period6	00 : 00 : 00	-	23 : 59 : 59

At the bottom of the window are "Cancel" and "Confirm" buttons.

- 2) Click **Setup** corresponding to the day you need to configure time period.
- 3) Select the period you need to enable, and enter start time, and end time of corresponding period.
- 4) If you need to apply this period setting to any other day, select the check box of corresponding days.
- 5) Click **Confirm**.

You can repeat these steps to apply the settings to other days.

Step 5 Set other parameters.

Table 4-36 Relay activation parameter

Parameter	Description
Anti-dither	Enter anti-dither time (1 s–100 s). System will only record one when there are multiple alarms during the defined time..
Sensor Type	Select relay-in type according to the connected alarm input device. <ul style="list-style-type: none"> • NO: Low level valid. • NC: High level valid.
Relay-out	Optocoupler output. Select the check box to activate corresponding alarm output device when alarm occurs.
Signal Duration	The time that delays alarm when alarm occurs.

Step 6 Click **Confirm**.

4.5.4.1.2 Relay-out

You can trigger one alarm output signal.

Step 1 Select **Setting > Event > Alarm > Relay-out**.

Figure 4-71 Relay-out

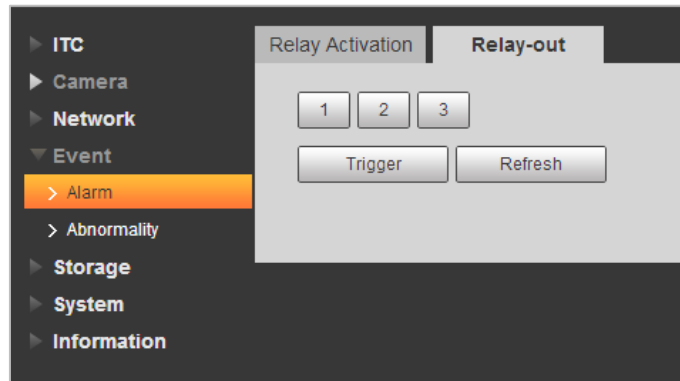

Step 2 Click **1, 2** or **3** to set one alarm channel.

Step 3 Set alarm output.

- Click **Trigger** to output relay-out signal. For example, if the Camera connects with an external buzzer, when clicking **Trigger**, and the buzzer buzzes, meaning the alarm output works properly.
- Click **Refresh** to refresh alarm output status.

4.5.4.2 Abnormality

Set relay-out mode of different events. When abnormality happens, system triggers alarm.

Step 1 Select **Setting > Event > Abnormality**.

Step 2 Select events from SD card, network error, illegal access, security exception and blacklist car as needed.

Figure 4-72 No storage card





Step 3 (Optional) Select event type. You only need to select this for SD card and network error.

Step 4 Click **On** to enable various abnormalities.

Step 5 Configure parameters of each event.

Table 4-37 Abnormality parameters description

Parameter	Description
Enable	Check to enable corresponding abnormality event.
Relay-out	Check to enable the corresponding alarm output of abnormality event, and select the corresponding port.
Signal Duration	The alarm linkage keeps running for the defined time after alarm ends. The time range is 10 s–300 s.
Capacity Limit	Configure the storage available that triggers abnormality alarm.  Only need to configure when setting Event Type to Scarcity of Storage Space in SD Card .
Login Error	Configure the number of login error allowed. The range is 3–10 times.  Only need to configure when setting Illegal Access .
Send Email	The system sends an email to the defined email address when an alarm is triggered. To set the email address, go to Setting > Network > SMTP(Email) .  Only need to configure when setting Illegal Access and Blocklist Car .

Step 6 Click **Confirm**.

4.5.5 Storage

This section provides guidance on setting associated information of storage, and record control.

4.5.5.1 Point

Set the storage path of snapshot.

Step 1 Select **Setting > Storage > Destination > Point**.

Figure 4-73 Point

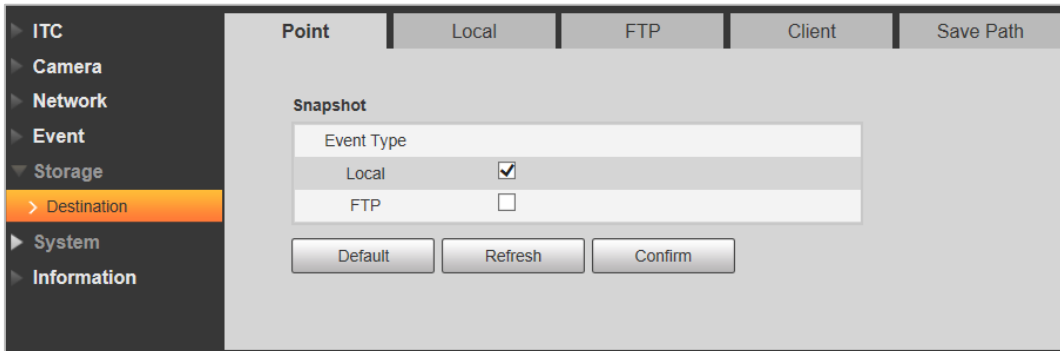

Step 2 Select **Event Type**.

- **Local:** Store into the TF card.
- **FTP:** Store into the FTP server.

Step 3 Click **Confirm**.

4.5.5.2 Local

Display the information of local SD card. You can set hot swap, and format SD card.



Format the SD card before use.

Step 1 Select **Setting > Storage > Destination > Local**.

- Select **Overwrite** or **Stop** from **Disk Full**, meaning overwrite the records or stop storing new pictures or videos respectively when disk is full.
- View the storage information of the card.
- Click **Hot Swap**, and then you can pull out the SD card.
- Click **Format**, and then you can format the SD card.

Figure 4-74 Local configuration parameter description

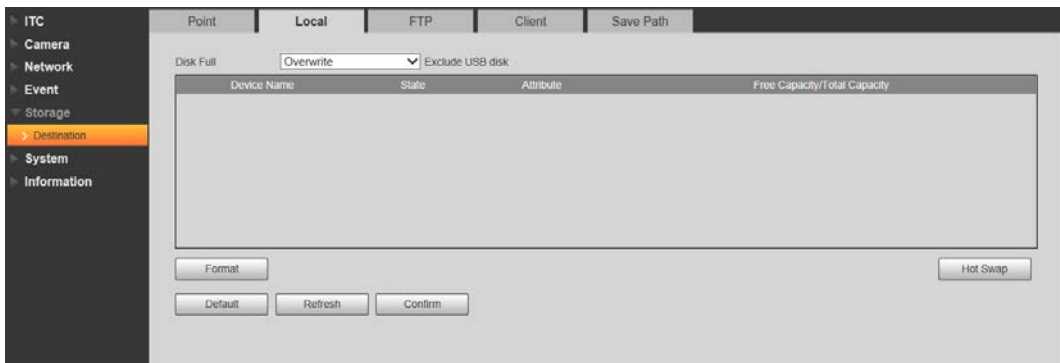

Step 2 Click **Confirm**.

4.5.5.3 FTP

FTP function can be enabled only when it is selected as destination path. When the network does

not work, you can save all the files to the internal SD card for emergency.



You can set picture name, and storage path. Click **Help...** to view naming rule.

Step 1 Select **Setting > Storage > Destination > FTP**.

Figure 4-75 FTP

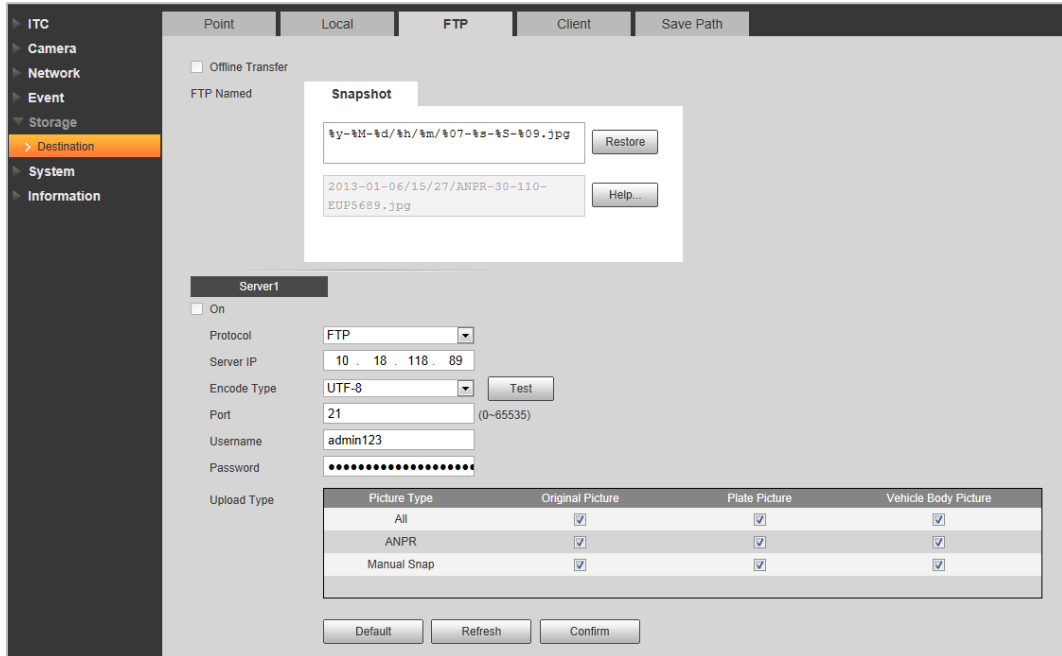

Step 2 Configure parameters.

Table 4-38 FTP configuration parameter description

Parameter	Description
Offline Transfer	When the network disconnects or fails, snapshots will be stored in TF card. After the network is restored, the snapshots will be uploaded from the TF card to FTP or client. Make sure that TF card is inserted in the Camera; otherwise, the offline transfer function cannot be enabled.
FTP Named	Set the naming rule of snapshots to be saved in FTP server. You can click Help... to view the Picture Naming Help , or click Restore to restore the default naming rule.
On	Enable FTP server storage.
Protocol	<ul style="list-style-type: none"> ● SFTP (Recommended): Secure File Transfer Protocol, a network protocol allows file access, and transfer over a secure data stream. ● FTP: File Transfer Protocol, a network protocol implemented to exchange files over a TCP/IP network. Anonymous user access is also available through an FTP server.
Server IP	The IP address of FTP server.
Encode Type	Refers to the encode mode of Chinese characters when naming pictures. Two modes are available: UTF-8 , and GB2312 . After configuring Server IP , and Port , click test to check whether the FTP server works.
Port	The port number of FTP server.
Username	The username, and password of FTP server.

Parameter	Description
Password	
Upload Type	Select event(s), and picture type(s) to be uploaded to the FTP server.

Step 3 Click **Confirm**.

4.5.5.4 Client

You can set the parameters of storing to client.

Step 1 Select **Setting > Storage > Destination > Client**.

Figure 4-76 Client

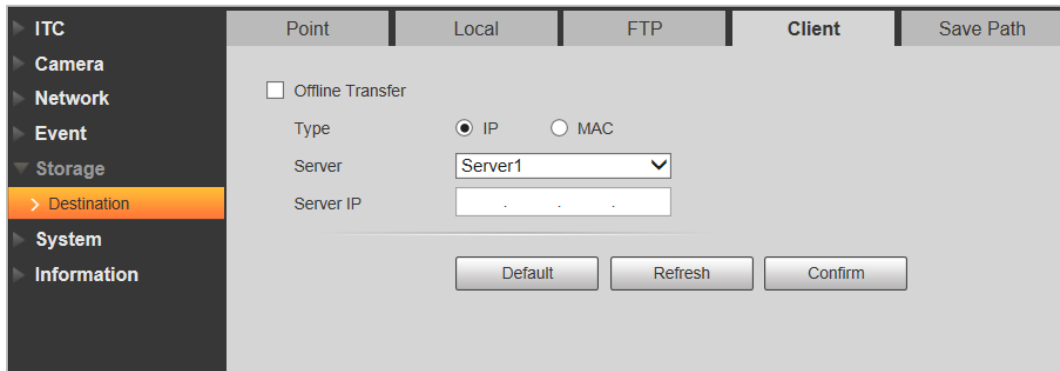

Step 2 Configure parameters.

Table 4-39 Client configuration parameter description

Parameter	Description
Offline Transfer	When network is disconnected or failed, you can store the picture into local storage card, and it will automatically upload to platform server after network resumes.
Type	Select connection type with platform server. <ul style="list-style-type: none"> ● IP: Connect to platform server through IP address. ● MAC: Connect to platform server through MAC address.
Server	Select server, which includes Server1, and Server2.
Server IP	<ul style="list-style-type: none"> ● When the type is selected as IP, you need to fill in IP address of the server. ● When the type is selected as MAC, you need to fill in MAC address of the server.

Step 3 Click **Confirm**.

4.5.5.5 Save Path

This section provides guidance on configuring picture, record naming, and storage path.

Step 1 Select **Setting > Storage > Destination > Save Path**.

Figure 4-77 Storage path

- Step 2 According to your actual requirement, set the name of picture, and storage path. See **Help...** for more details.
- Step 3 Set the root path for recordings and snapshots.
- Step 4 Click **Confirm**.

4.5.6 System

You can configure general information, adding user, restoring default settings, and configuring import & export file.

4.5.6.1 General

4.5.6.1.1 General Setup

This section provides guidance on configuring device SN, language, and video standard.

- Step 1 Select **Setting > System > General Setting > General Setup**.

Figure 4-78 General

- Step 2 Configure parameters.

Table 4-40 General parameters description

Parameter	Description
Device SN	The ID number of the Camera. Supports English letters, and numbers.
Device Code	Device Code Failed to support OSD information overlay.
Language	The language displayed on web. The language will be automatically switched after logging in web again. Currently it only supports English.
Video Standard	<ul style="list-style-type: none"> • PAL: Phase Alternating Line. Currently most countries around the world (including most countries in Europe, Africa, Australia, and China) adopt this standard. • NTSC: National Television System Committee. The main countries which adopt this standard include America, Canada, and Japan.
Machine Group	The company group information of the Camera.
Machine Address	Set the location information of device capture.

Step 3 Click **Confirm**.

4.5.6.1.2 Date & Time

You can set date, and time format, system time, DST (Daylight Saving Time) or NTP server, and more.

Step 1 Select **Setting > System > General > Date&Time**.

Figure 4-79 Date & time

Step 2 Configure parameters.

Table 4-41 Date & time parameter description

Parameter	Description
Date Format	Select date format.
Time Format	Select 24-Hour or 12-Hour system.

Parameter	Description
System Time	Set current system time of the Camera. It becomes valid immediately after setting.
Sync PC	Sync the time of the Camera with the time on PC.
DST	Enable the function, and then set begin time, and end time of DST according to date or week.
NTP Setting	Select to enable the function of network time synchronization.
NTP Server	Time server address.
Port	Port number of time server.
Time Zone	The time zone where the Camera is located.
Interval	The sync interval between device, and time server.

Step 3 Click **Confirm**.

4.5.6.2 Account

4.5.6.2.1 Account

The system supports configuring operation user of web. You need to configure user group before configuring user account.



- The user with **Account** control authority can also change the password of other users.
- It is recommended to give fewer authorities to normal users than premium users to make user management convenient.
- Cannot delete the user in login status.

You can add, delete or modify user.

Procedure

Step 1 Select **Setting > System > Account > Account > Username**.

Figure 4-80 Username

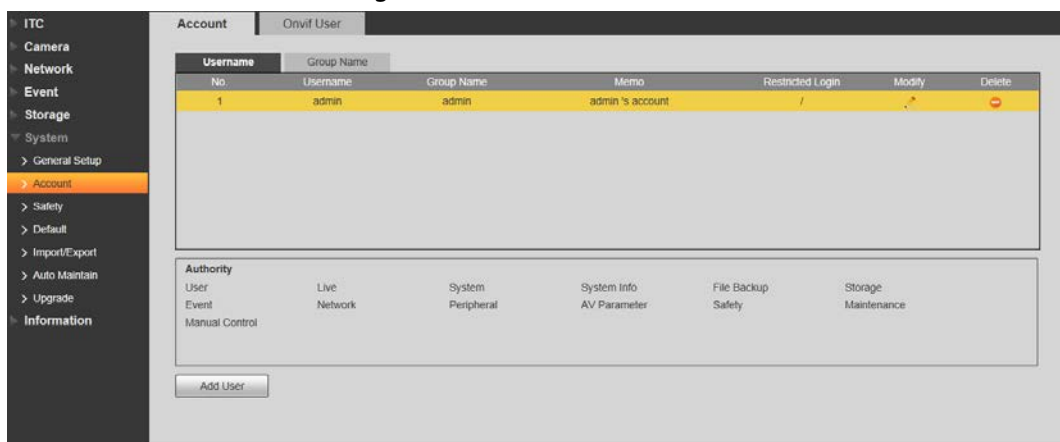

Step 2 Click **Add User**.

Figure 4-81 Add user

Step 3 Configure parameters.

Table 4-42 Add user parameters description

Parameter	Description
Username	Username It can only consist of number, letter, underline, and hyphen, the maximum length contains 15 characters, and it cannot be the same as the existed username.
Password	User's password, and confirm password.
Confirm Password	<ul style="list-style-type: none"> The password can be set from 8 characters to 32 nonblank characters, and contains at least two categories from upper cases, lower cases, numbers, and special characters (excluding "", "", ";", ":", and "&") Follow the password security prompt to set a high security level password. Password should be the same as Confirm Password.
Group Name	Select the group to which new users belong. Each group has different authorities.
Memo	Remarks of the user.
Operation Permission	Select the permissions that you want assign to the user.
Restricted Login	Set the IP address that is restricted to log in, and the restriction time.

Step 4 Click **Save**.

Step 5 Select **Setting > System > Account > Account > Group Name**.

You have two groups named admin, and user by default, you can add new group, delete added group or modify group authority, and memo.



- The system supports max 8 user groups, and the default initialization user groups are **admin**, and **user**.
- You can modify, and delete the added user group, but not the initialization user group.

Figure 4-82 User group

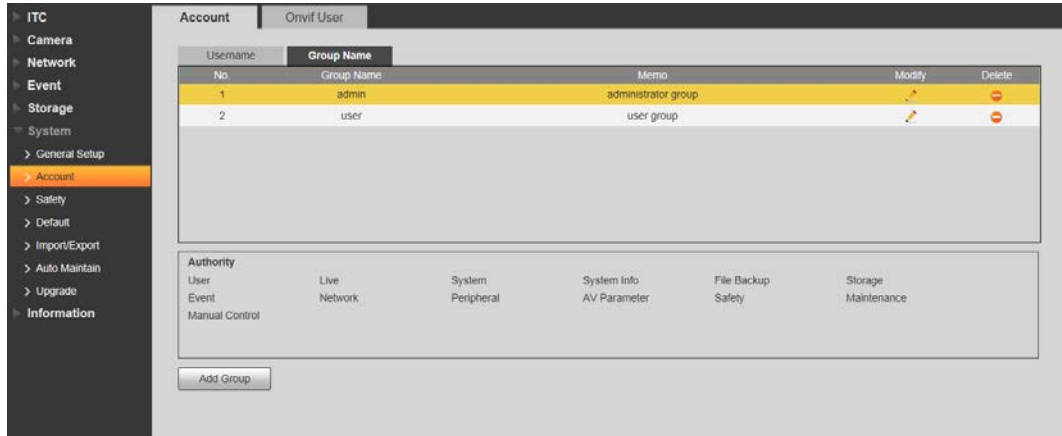

Step 6 Click **Add Group**, and then enter the name of user group, and configure group authority.

- **Group Name** can only consist of number, letter, underline, and hyphen, the maximum length contains 15 characters.
- **Group** cannot be repeated.

Figure 4-83 Add group

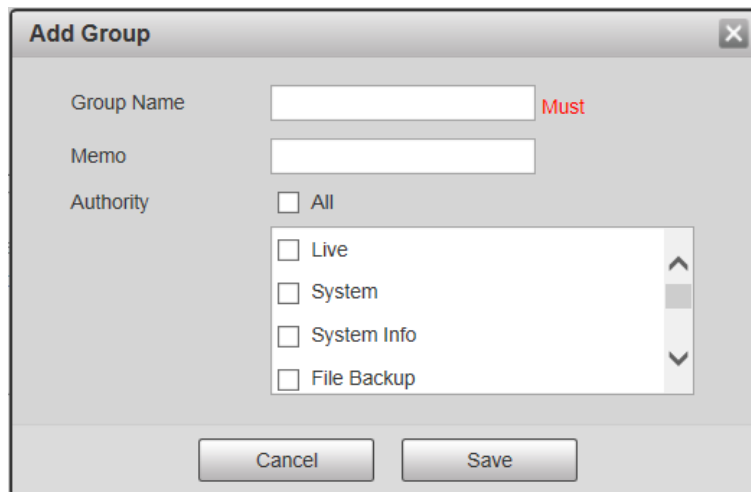

Step 7 Click **Save**.

Related Operations

After adding user/group, click to change user/group information; click to delete the added user/group.



Admin user/group cannot be deleted.

4.5.6.2.2 ONVIF User

You can add, delete, modify Onvif (Open Network Video page Forum) on the user management page.

Step 1 Select **Setting > System > Account > Onvif User**.

Figure 4-84 Onvif user

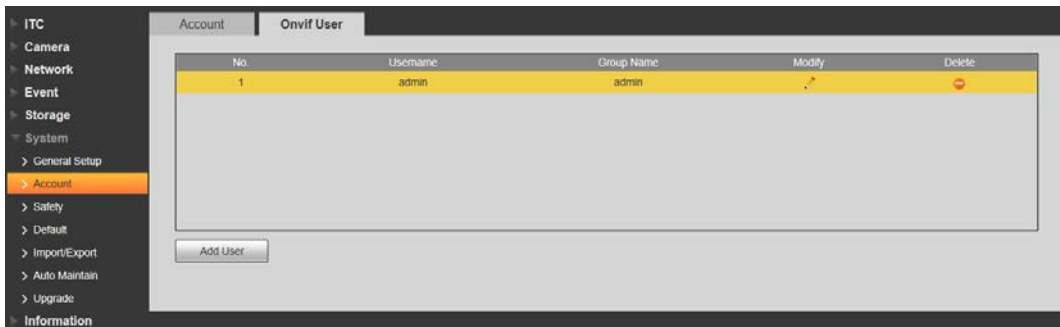

Step 2 Click **Add User**.

Figure 4-85 Add user

Step 3 Configure parameters.

Table 4-43 User parameter description

Parameter	Description
Username	The unique identification of user. You cannot use existing user name.
Password	The password of user, and confirm password.
Confirm Password	<ul style="list-style-type: none"> The password can be set from 8 characters to 32 nonblank characters, and contains at least two types from upper case, lower case, number, and special characters (excluding ' " ; : &) Follow the password security notice to set a high security level password. The new password should be in accordance with the confirm password.
Group Name	The group that users belong to. Each group has different authorities.

Step 4 Click **Save**.

- After adding user, click to change user password, group, memo, and authorities; click to delete the added user, admin user cannot be deleted.
- Click in the admin row to modify user name, and email address.

4.5.6.3 Safety

4.5.6.3.1 System Service

Select to enable system services as needed.

Step 1 Select **Setting > System > Safety > System Service**.

Figure 4-86 System Service

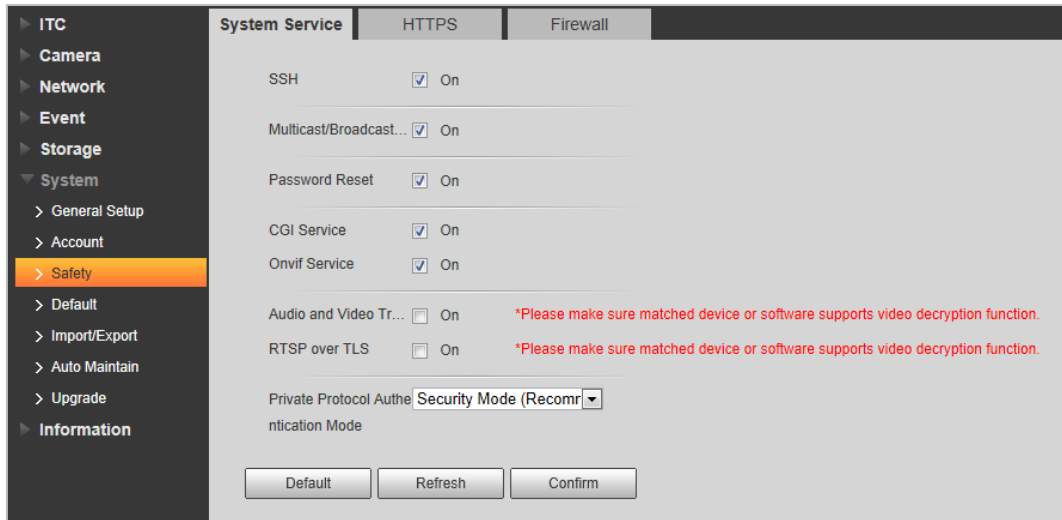

Step 2 Select needed system service.

Table 4-44 System service parameters description

Parameter	Description
SSH	SSH (Secure Shell) implements data encrypted transmission, and effectively avoid information leakage during remote management.
Multicast/Broadcast Search	<ul style="list-style-type: none"> ● Multicast: It realizes point-to-multipoint network connection between sender, and receiver. ● Broadcast Search: Broadcast data packet in IP subnet, all the hosts in the subnet will receive these data packets.
Password Reset	When you forget the password of admin user, you can set new password through password reset function.
CGI Service	CGI is the port between external application program, and web server.
Onvif Service	Realizes network video framework agreement to make different network video products interconnected.
Audio and Video Transmission Encryption	Enable this function to encrypt streams transmitted through private protocols.
RTSP over TLS	Enable this function to encrypt stream transmitted through standard protocol. It is recommended to keep the function on.
Private Protocol Authentication Mode	Keep the recommended Security Mode .

Step 3 Click **Confirm**.

4.5.6.3.2 HTTPS

Prerequisites

- For first-time use of HTTPS or after changing device IP address, you need to create server certificate, and install root certificate.
- After creating server certificate, and installing root certificate, if it replaces the PC, which logs in to the web page, then it needs to download, and install the root certificate again on the new PC or copy the downloaded root certificate on the new PC, and install.

On the **HTTPS** page, users can make PC log in normally through HTTPS by creating certificate or uploading authenticated certificate. It can ensure security of communication data, and provide guarantee for user information, and device safety through reliable, and stable technical approach.

Procedure

- Step 1** Create certificate or upload the authenticated certificate.
- If you select **Create Certificate**, follow the steps below.
 1. Select **Setting > System > Safety > HTTPS**.

Figure 4-87 HTTPS

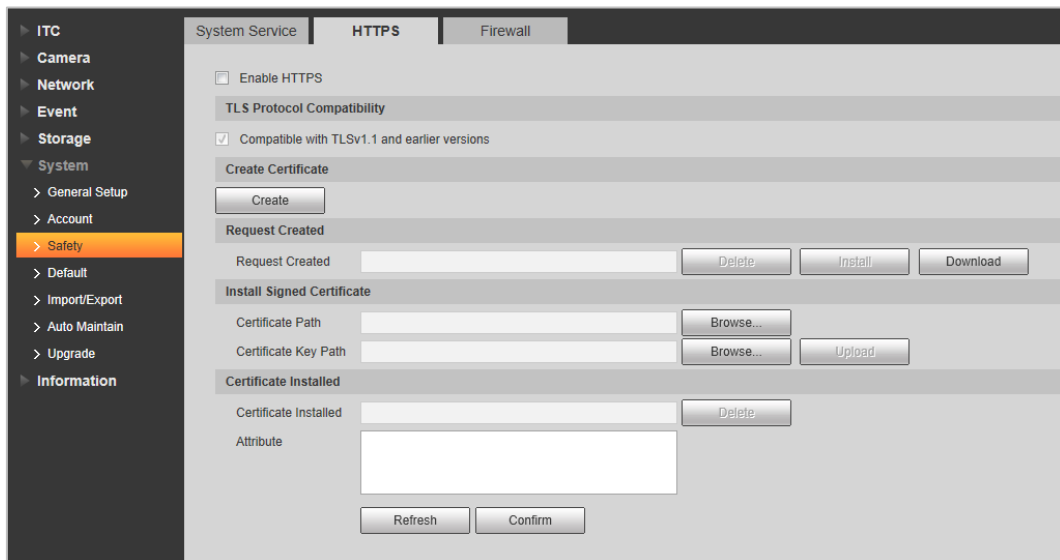

The screenshot shows the 'HTTPS' configuration page. On the left is a navigation menu with 'Safety' selected. The main content area has tabs for 'System Service', 'HTTPS', and 'Firewall'. Under the 'HTTPS' tab, there are sections for 'Enable HTTPS', 'TLS Protocol Compatibility', 'Create Certificate', 'Request Created', 'Install Signed Certificate', and 'Certificate Installed'. The 'Create Certificate' section has a 'Create' button. The 'Request Created' section has a table with columns for 'Request Created', 'Delete', 'Install', and 'Download'. The 'Install Signed Certificate' section has fields for 'Certificate Path' and 'Certificate Key Path', each with a 'Browse...' button, and an 'Upload' button. The 'Certificate Installed' section has a 'Certificate Installed' field with a 'Delete' button and an 'Attribute' field. At the bottom are 'Refresh' and 'Confirm' buttons.

2. Click **Create**.

Figure 4-88 HTTPS

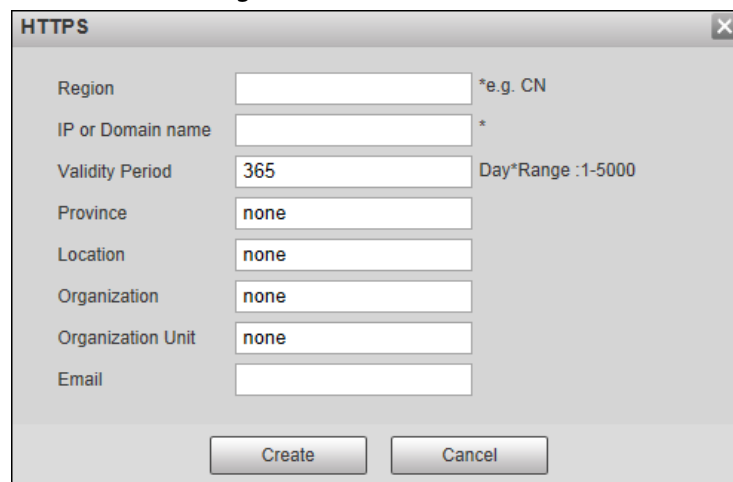

The screenshot shows a dialog box titled 'HTTPS'. It contains several input fields: 'Region' (with a hint '*e.g. CN'), 'IP or Domain name' (with a hint '*'), 'Validity Period' (with a value of 365 and a hint 'Day*Range :1-5000'), 'Province' (with a value of none), 'Location' (with a value of none), 'Organization' (with a value of none), 'Organization Unit' (with a value of none), and 'Email'. At the bottom are 'Create' and 'Cancel' buttons.

3. Enter the required information such as region, IP or domain name, and then click **Create**.



The entered **IP or Domain name** must be the same as the IP or domain name of the Camera.

4. Click **Install** under **Request Created**, and then click **Download** to download root certificate.
The system pops up **Save As** dialog box, select storage path, and then click **Save**.
5. Double-click the RootCert.cer icon.
6. Click **Install Certificate...**

Figure 4-89 Install certificate

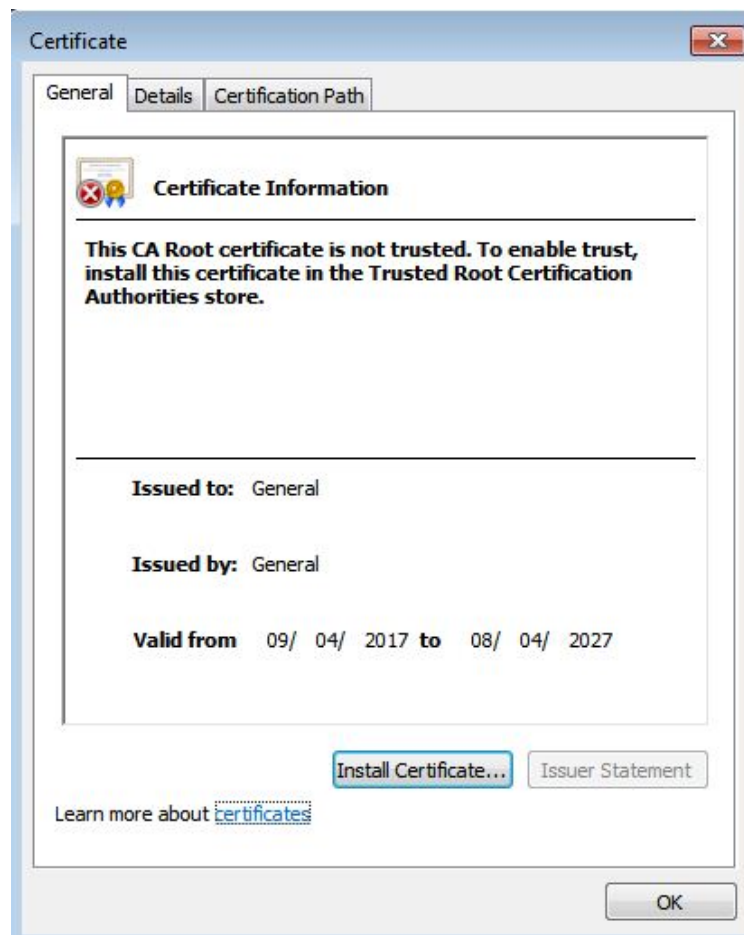

7. Click **Next**.

The **Certificate Store** page is displayed. You can select automatically select the certificate store based on the type of certificate or place all certificates in custom certificate store.

Figure 4-90 Certificate store

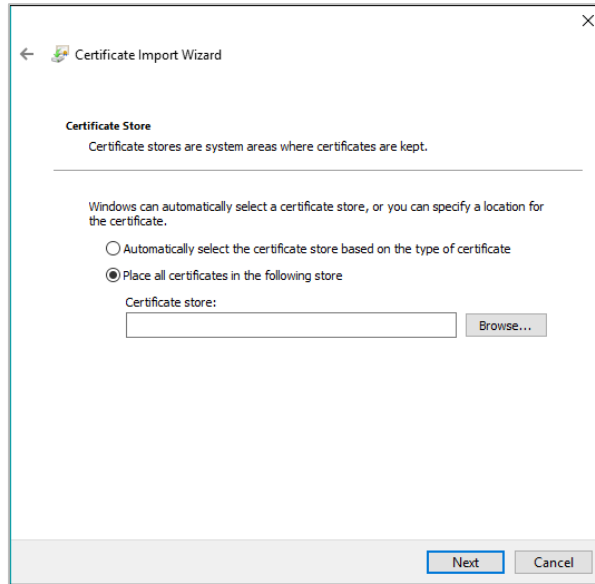

8. Click **Next**.

Figure 4-91 Completing certificate import wizard

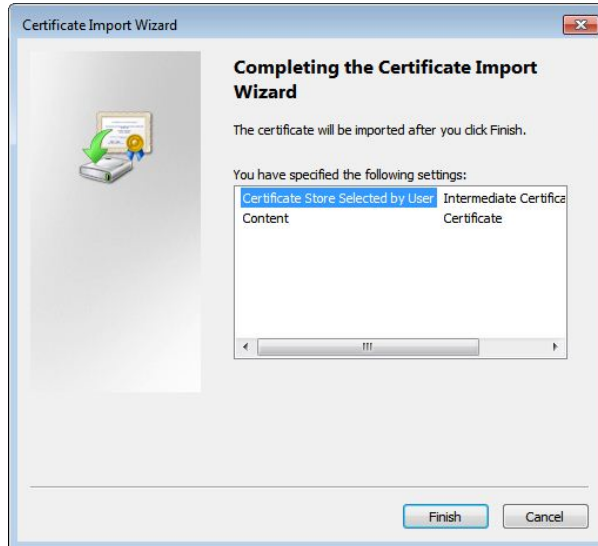

9. Click **Finish**.

Figure 4-92 Security warning

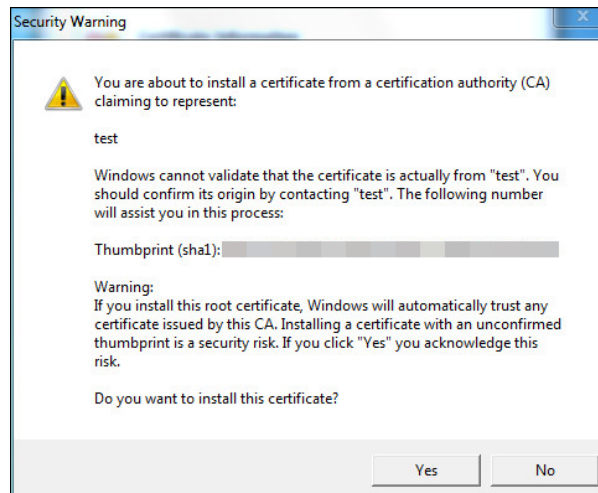

10. Click **Yes**, and then click **OK** on the pop-up window.
- If you select **install signed certificate**, follow the steps below.
 1. Select **Setting Safety > System > Safety > HTTPS**.
 2. Select **Enable HTTPS**, and **Compatible with TLSv1.1, and earlier versions**.
 3. Click **Browse** to upload the signed certificate, and certificate key, and then click **Upload**.
 4. To install the root certificate, see operation steps from 1.d to 1.j in **Create Certificate**.

Step 2 Select **Enable HTTPS**, and click **Confirm**.

The configuration takes effect until the Camera restarts.

Step 3 Use HTTPS to log in to the Camera.

1. Enter `https://xx.xx.xx.xx` in the browser.



`xx.xx.xx.xx` is the device IP address or domain name.

2. Enter the username, and password to log in to the Camera.

The browser will prompt certificate error if certificate is not installed.

Figure 4-93 Restart device

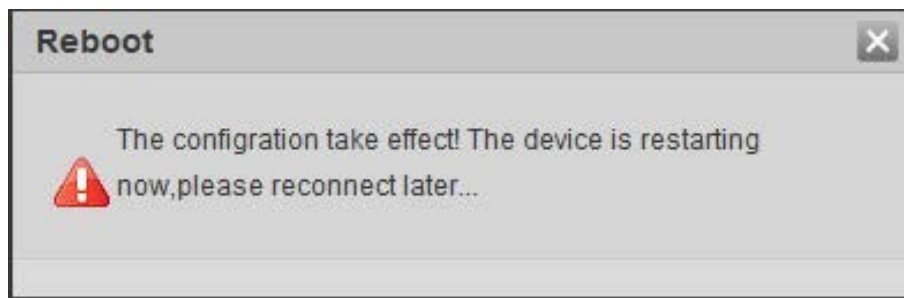

4.5.6.3.3 Firewall

Set the security rules to protect the safety of your camera system.

Step 1 Select **Setting > System > Safety > Firewall**.

Figure 4-94 Firewall

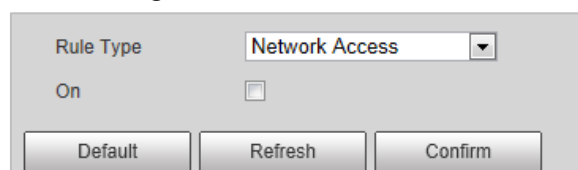

Step 2 Select **Rule Type**.



- **Network Access:** Add the IP address to allowlist or blocklist to allow or restrict it to access corresponding ports of the device.
- **PING Prohibited:** IP address of your camera is prohibited from ping. This helps prevent attempt of accessing your network system without permission.
- **Prevent Semijoin:** Prevents half-open SYN attacks.

Step 3 Select **On** to enable the selected rule type.

Step 4 Click **Confirm**.

4.5.6.4 Default Settings

You can restore the device to default settings or factory defaults.

Select **Setting > System > Default**, and then select **Default** or **Factory Default** as needed.

- **Default:** Restore your settings to default value. In this case, network IP address information of the Camera will not restore to default settings.
- **Factory Default:** Restore the system to factory default settings. In this case, the Camera will restart, and you need to initialize the Camera before any further operation.

Figure 4-95 Default settings

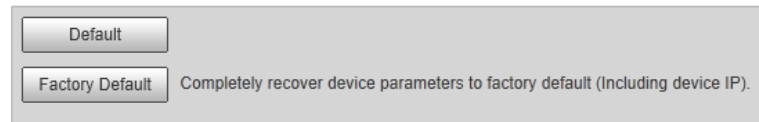

4.5.6.5 Import/Export

Export the system configuration file to back up the system configuration; import system configuration file to make quick configuration or recover system configuration.

Step 1 Select **Setting > System > Import/Export**.

Figure 4-96 Import/Export

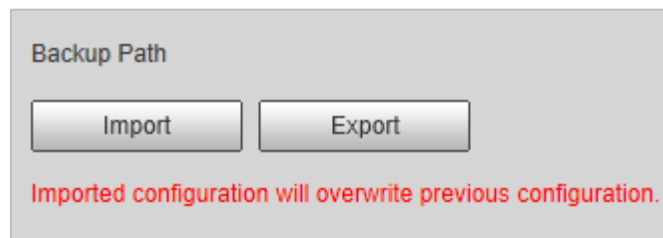

Step 2 Click **Import** or **Export**.

- **Import:** Import the local system configuration file to the system.
- **Export:** Export associated configuration to local, and save as file whose suffix is .backup.

Step 3 Select the imported file path or exported folder.

Step 4 Click **Open** or **Save**, and view import, and export result on the web page.

4.5.6.6 Automatic Maintenance

You can set the time of auto reboot, and automatically delete old files.

Step 1 Select **Setting > System > Auto Maintain**.

Figure 4-97 Auto maintain

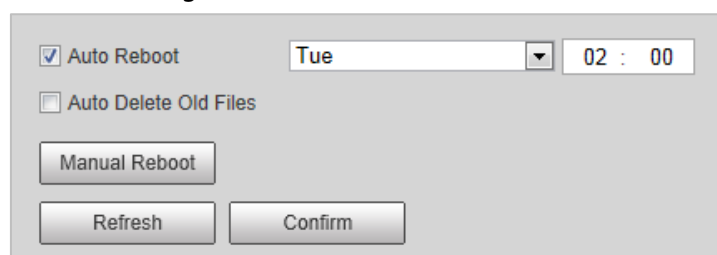

Step 2 Configure parameters.

Table 4-45 Auto maintain parameter description

Parameter	Description
Auto Reboot	<ul style="list-style-type: none"> Select, and set restart period, and time. The system will automatically restart within the defined period, and time.
Auto Delete Old Files	Customize time, and delete all the old files before the time.
Manual Reboot	Manually restart the Camera.

Step 3 Click **Confirm**.

4.5.6.7 System Upgrade

Upgrade system of the Camera to keep the camera functions always working. You can upgrade the system by using upgrade file or through online upgrade.

- Upgrading the wrong program might result in the Camera not working properly.
- During upgrading, make sure that the Camera is not disconnected from power, and network, and restart or shut down the web.
- Online upgrade is not supported in the current version. Do not select **Online Upgrade** on the web page.

Step 1 Select **Setting > System > Upgrade**.

Figure 4-98 System upgrade

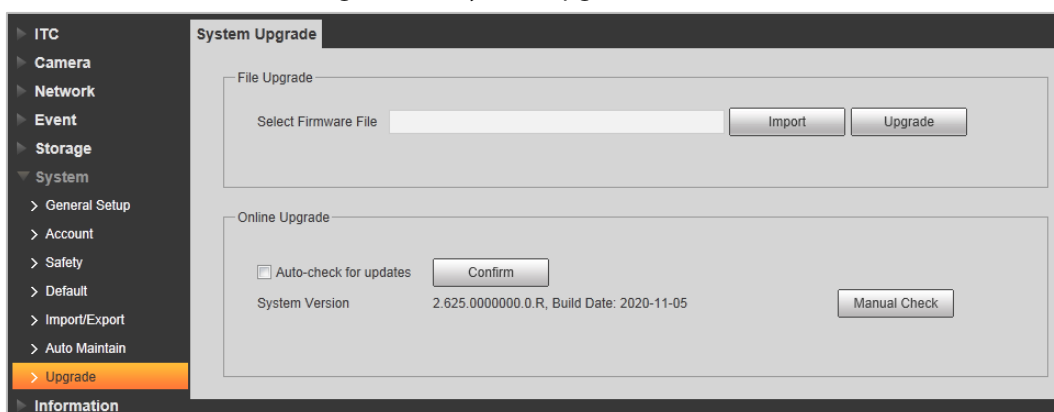

Step 2 Click **Import**, and import upgrade file (.bin).

Step 3 Click **Upgrade**.

The system starts to upgrade firmware.

4.5.7 Information

The system supports viewing version, user, and log, and more.

4.5.7.1 Version

You can view the version information of the Camera.

Select **Setting > Information > Version** .



- Versions of different devices might vary, depending on the actual web page.
- Algorithm recognition is available when algorithm is authorized (when the icon is displayed in green). If algorithm is not authorized, the Camera will not be able to recognize vehicle series, model, and logo. License plate recognition is always supported.

Figure 4-99 Version

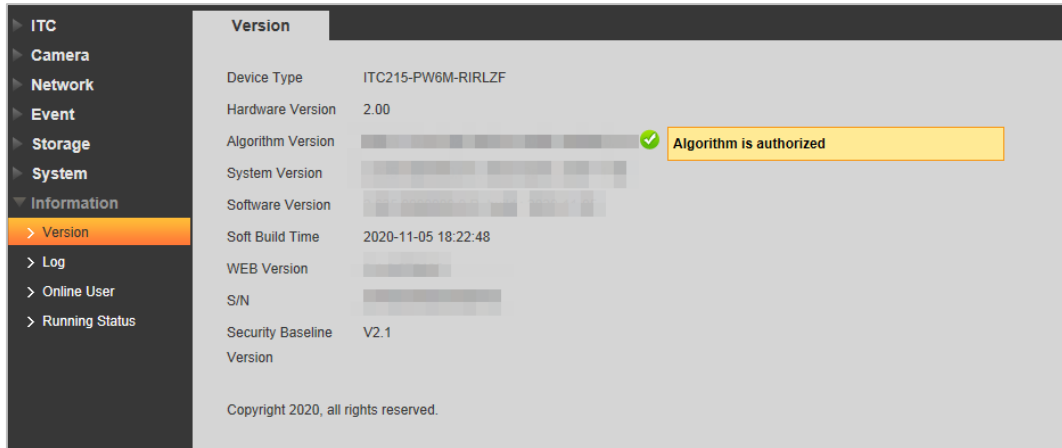

4.5.7.2 Log

4.5.7.2.1 System Log

You can view log information such as system, configuration, data, event, record, user management, and also clear log records.



The earliest log records will be overwritten when the number of log records reaches 1024.

Step 1 Select **Setting > Information > Log > Log**.

Figure 4-100 Log

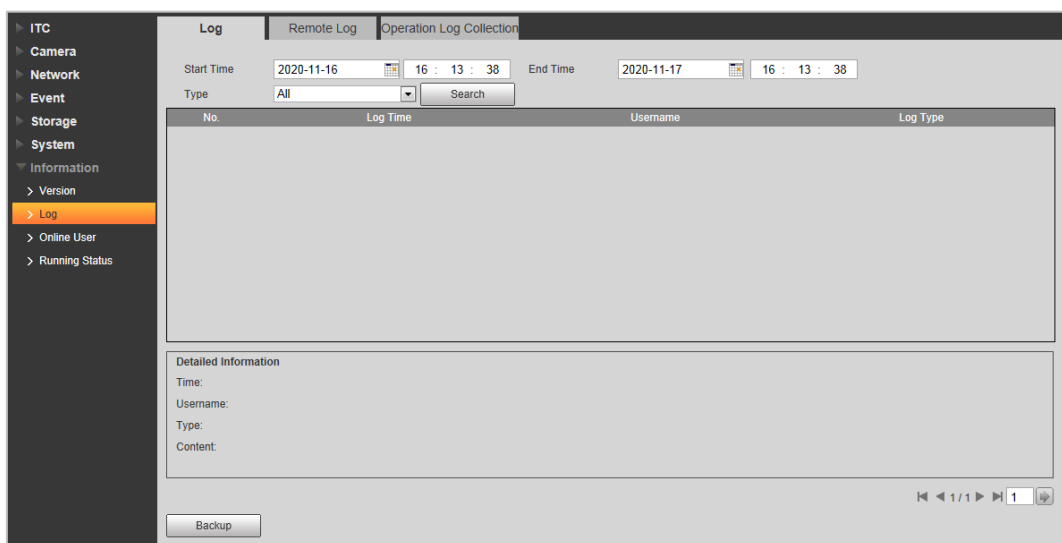

Step 2 Enter **Start Time**, and **End Time**, and then select log type.

Step 3 Click **Search**, and it can start searching according to requirement.

Step 4 View, back up, and clear the searching results.

Backup: Backup the searched system log information to local. The backup file is in .txt format.

4.5.7.2.2 Remote log

You can save your important logs to log server. This helps provide important clues to the source of security incidents. Log server needs to be deployed in advance by a professional or system administrator.

Step 1 Select **Setting > Information > Log > Remote Log**.

Figure 4-101 Remote log

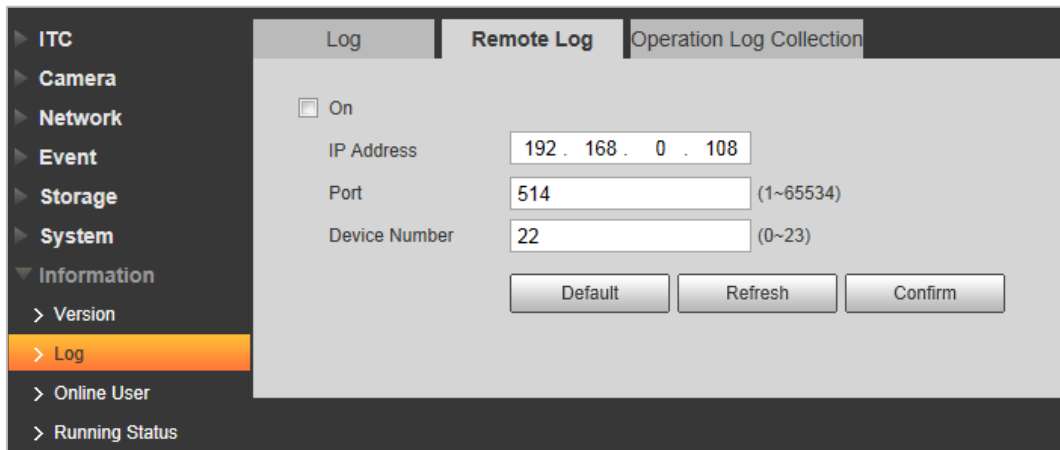

Step 2 Select **On** to enable remote log.

Step 3 Configure the IP address, port, and device number.

Step 4 Click **Confirm**.

4.5.7.2.3 Operation Log Collection

Enable this function can collect operation log in real time, which can be used to troubleshoot in the future.

Step 1 Select **Setting > Information > Log > Operation Log Collection**.

Step 2 Check **On** to enable the log collection.

Figure 4-102 Operation log collection

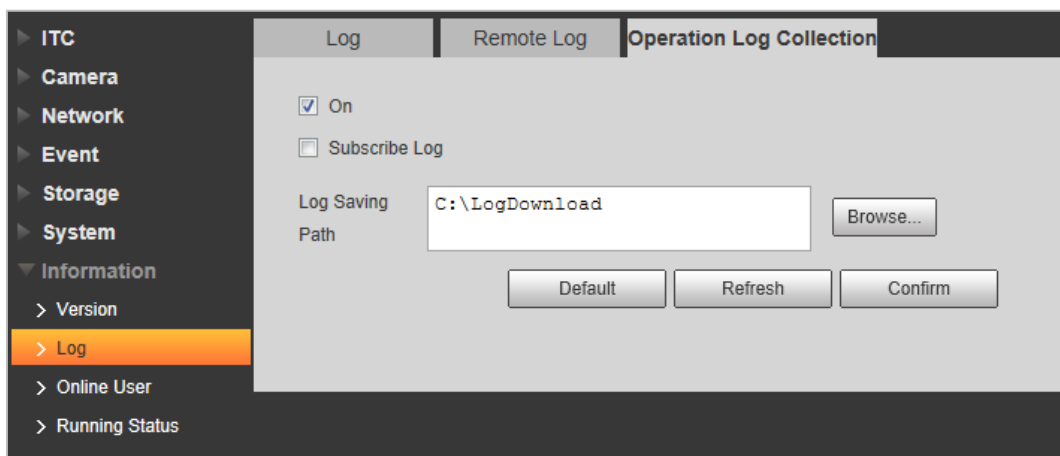

Step 3 Click **Browse** to set the log save path.

Step 4 Select whether to enable **Subscribe Log** as needed.

Step 5 Click **Confirm**.

4.5.7.3 Online User

Select **Setting** > **Information** > **Online User** to view the information of all the online users.

Figure 4-103 Online user

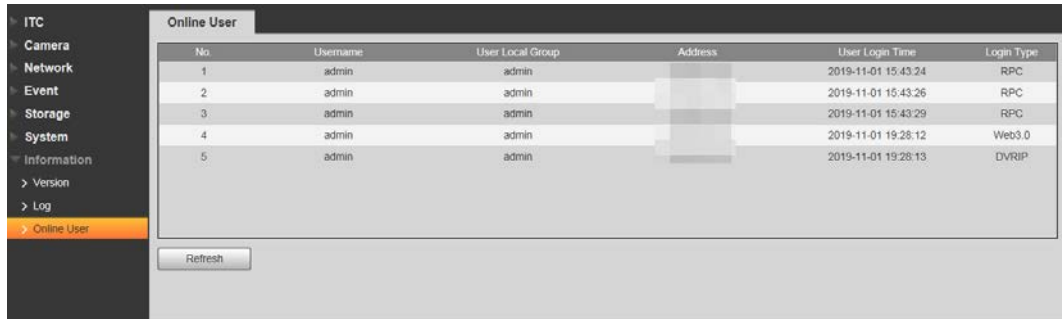

The screenshot shows a web interface with a sidebar on the left containing menu items: ITC, Camera, Network, Event, Storage, System, Information, Version, Log, Online User, and Running Status. The 'Online User' menu item is highlighted. The main content area is titled 'Online User' and contains a table with the following data:

No.	Username	User Local Group	Address	User Login Time	Login Type
1	admin	admin		2019-11-01 15:43:24	RPC
2	admin	admin		2019-11-01 15:43:26	RPC
3	admin	admin		2019-11-01 15:43:29	RPC
4	admin	admin		2019-11-01 19:28:12	Web3.0
5	admin	admin		2019-11-01 19:28:13	DVRIP

Below the table is a 'Refresh' button.

Click **Refresh** to view the latest status.

4.5.7.4 Running Status

Select **Setting** > **Information** > **Running Status** to view the system running time.

Figure 4-104 Running status

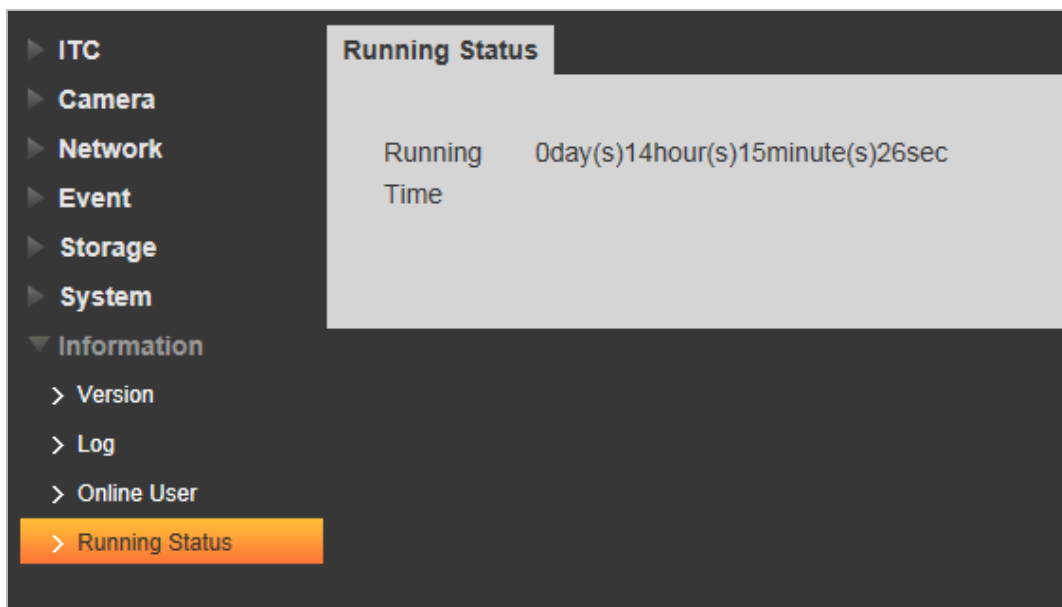

The screenshot shows a web interface with a sidebar on the left containing menu items: ITC, Camera, Network, Event, Storage, System, Information, Version, Log, Online User, and Running Status. The 'Running Status' menu item is highlighted. The main content area is titled 'Running Status' and displays the following information:

Running Time	0day(s)14hour(s)15minute(s)26sec
--------------	----------------------------------

4.6 Alarm

Click the **Alarm** tab, and then you can select alarm type, operation, and alarm tone.

Figure 4-105 Alarm

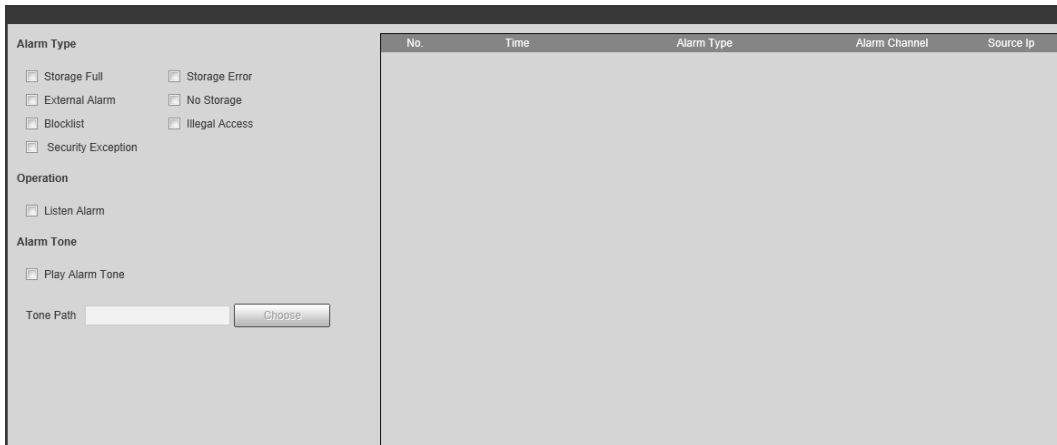

Table 4-46 Alarm parameters description

Type	Parameter	Description
Alarm Type	Storage Full	It triggers alarm when storage card is full.
	Storage Error	It triggers alarm when storage card fault occurs.
	External Alarm	It generates alarm through peripheral device when alarm is triggered.
	No Storage	It triggers alarm when there is no storage card.
	Blocklist	It triggers alarm when the blocklist vehicle appears.
	Illegal Access	It triggers alarm when the times of login password error reach the max value.
Operation	Listen Alarm	It triggers alarm when there is security exception.
	Listen Alarm	The web will prompt user when device alarm occurs.
Alarm Tone	Play Alarm Tone	It generates alarm prompt tone when alarm occurs. Alarm tone supports customized settings.
	Tone Path	The path of customized alarm tone.

4.7 Logout

Click **Logout** to exit the system. You need to log in again for access.

Figure 4-106 Login again

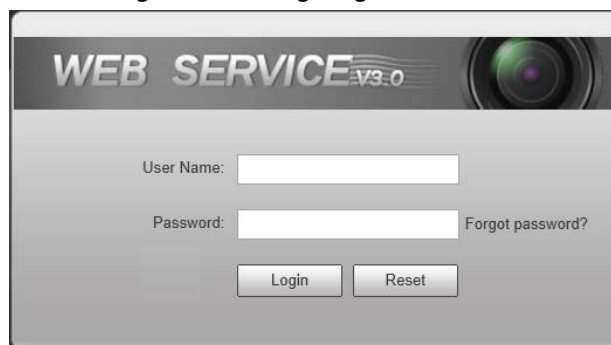

5 FAQ

Question	Solution
Device error, unable to start or operate normally	Press, and hold Reset button for 5 seconds to restore the Camera to factory default Settings.
TF card hot swapping	Stop recording, and image capturing, and then wait for at least 15 seconds before removing the TF card. This helps ensure data integrity, and avoid losing all the data of the card.
TF card read/write limit	Do not set the TF card as the storage media of pre-set recording. It may damage the TF card duration.
TF card cannot be used as storage media	When the TF card hibernates or its capacity is null, format the card through web first.
Network upgrade failed	Check whether the right upgrade program (such as version, compatibility) is used.
Recommended TF card	It is recommended to use TF card of 16 GB or above. This helps avoid data loss arising from insufficient capacity. You can use card of 16 GB, 32 GB, 64 GB, and 128 GB.
Failed to pop up the installation dialog box of web control webrec.cab	Set the security level of IE browser as Low , and Active Plug-in , and Control is set to Enable .

Appendix 1 Cybersecurity Recommendations

Mandatory actions to be taken for basic device network security:

1. Use Strong Passwords

Please refer to the following suggestions to set passwords:

- The length should not be less than 8 characters.
- Include at least two types of characters; character types include upper and lower case letters, numbers and symbols.
- Do not contain the account name or the account name in reverse order.
- Do not use continuous characters, such as 123, abc, etc.
- Do not use overlapped characters, such as 111, aaa, etc.

2. Update Firmware and Client Software in Time

- According to the standard procedure in Tech-industry, we recommend to keep your device (such as NVR, DVR, IP camera, etc.) firmware up-to-date to ensure the system is equipped with the latest security patches and fixes. When the device is connected to the public network, it is recommended to enable the "auto-check for updates" function to obtain timely information of firmware updates released by the manufacturer.
- We suggest that you download and use the latest version of client software.

"Nice to have" recommendations to improve your device network security:

1. Physical Protection

We suggest that you perform physical protection to device, especially storage devices. For example, place the device in a special computer room and cabinet, and implement well-done access control permission and key management to prevent unauthorized personnel from carrying out physical contacts such as damaging hardware, unauthorized connection of removable device (such as USB flash disk, serial port), etc.

2. Change Passwords Regularly

We suggest that you change passwords regularly to reduce the risk of being guessed or cracked.

3. Set and Update Passwords Reset Information Timely

The device supports password reset function. Please set up related information for password reset in time, including the end user's mailbox and password protection questions. If the information changes, please modify it in time. When setting password protection questions, it is suggested not to use those that can be easily guessed.

4. Enable Account Lock

The account lock feature is enabled by default, and we recommend you to keep it on to guarantee the account security. If an attacker attempts to log in with the wrong password several times, the corresponding account and the source IP address will be locked.

5. Change Default HTTP and Other Service Ports

We suggest you to change default HTTP and other service ports into any set of numbers between 1024–65535, reducing the risk of outsiders being able to guess which ports you are using.

6. Enable HTTPS

We suggest you to enable HTTPS, so that you visit Web service through a secure communication channel.

7. MAC Address Binding

We recommend you to bind the IP and MAC address of the gateway to the device, thus reducing the risk of ARP spoofing.

8. Assign Accounts and Privileges Reasonably

According to business and management requirements, reasonably add users and assign a minimum set of permissions to them.

9. Disable Unnecessary Services and Choose Secure Modes

If not needed, it is recommended to turn off some services such as SNMP, SMTP, UPnP, etc., to reduce risks.

If necessary, it is highly recommended that you use safe modes, including but not limited to the following services:

- SNMP: Choose SNMP v3, and set up strong encryption passwords and authentication passwords.
- SMTP: Choose TLS to access mailbox server.
- FTP: Choose SFTP, and set up strong passwords.
- AP hotspot: Choose WPA2-PSK encryption mode, and set up strong passwords.

10. Audio and Video Encrypted Transmission

If your audio and video data contents are very important or sensitive, we recommend that you use encrypted transmission function, to reduce the risk of audio and video data being stolen during transmission.

Reminder: encrypted transmission will cause some loss in transmission efficiency.

11. Secure Auditing

- Check online users: we suggest that you check online users regularly to see if the device is logged in without authorization.
- Check device log: By viewing the logs, you can know the IP addresses that were used to log in to your devices and their key operations.

12. Network Log

Due to the limited storage capacity of the device, the stored log is limited. If you need to save the log for a long time, it is recommended that you enable the network log function to ensure that the critical logs are synchronized to the network log server for tracing.

13. Construct a Safe Network Environment

In order to better ensure the safety of device and reduce potential cyber risks, we recommend:

- Disable the port mapping function of the router to avoid direct access to the intranet devices from external network.
- The network should be partitioned and isolated according to the actual network needs. If there are no communication requirements between two sub networks, it is suggested to use VLAN, network GAP and other technologies to partition the network, so as to achieve the network isolation effect.
- Establish the 802.1x access authentication system to reduce the risk of unauthorized access to private networks.
- Enable IP/MAC address filtering function to limit the range of hosts allowed to access the device.