

DH-PFM376-C

Mounting Bracket of Solar Panel

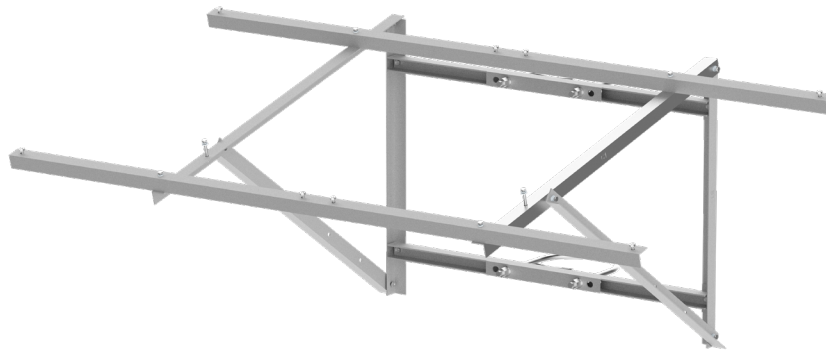

Technical Specification

Model	DH-PFM376-C		
Type	Mounting brackets of solar panel		
Material	Q235		
Surface treatment	Galvanized		
Installation	Pole mont		
Installation diameter	Φ150mm~Φ220mm(Φ5.91"~Φ8.66")		
Optional angle	15°	30°	45°
Suitable region(latitude)	0°~15°	16°~30°	31°~45°
Load bearing	30kg(66.14lb)		
Color	Silver grey		
Compatibility (solar panel model and quantity)	Suitable for the solar panel model of DH-PFM371-150/200 and support to install 2 pcs solar panels simultaneously.		
Package dimension & weight	2179mmx310mmx210mm(85.79"x12.2"x8.27") 36kg(79.37lb)		

Dimension(mm/inch)

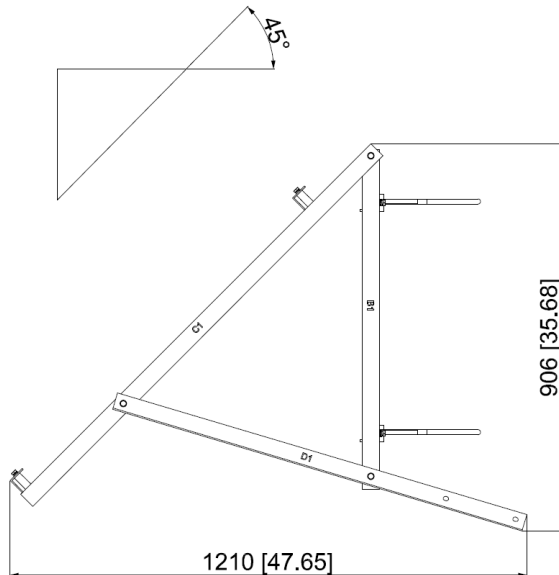
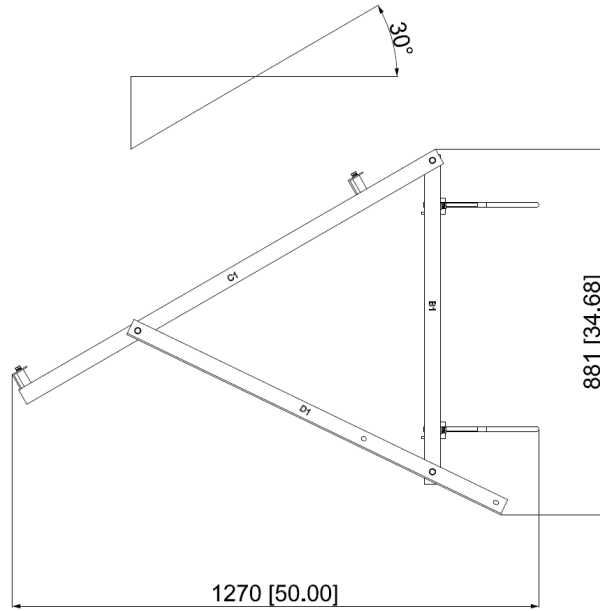
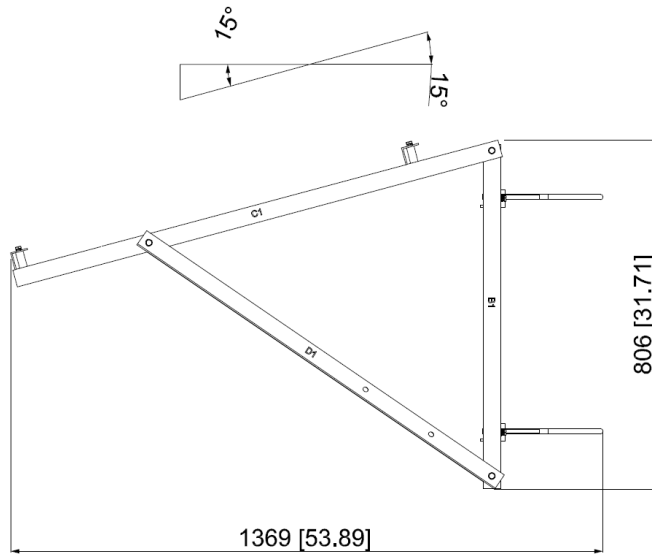

Application



Package Information

- Mounting bracket of solar panel DH-PFM376-C *1
- M8x25mm assembling bolt *14pcs
- M8x60mm assembling bolt *4pcs
- M16(double nut&spring pad&flat pad) components *4pcs
- M16 U-hoop *2pcs
- M8x25mm hex head screw *4pcs